



This book is provided in digital form with the permission of the rightsholder as part of a Google project to make the world's books discoverable online.



This book is licensed under a Creative Commons license. By using a Creative Commons license, the rightsholder chose to give you more freedom to share or re-use the book than would otherwise be possible under copyright law.

The rightsholder has waived all copyrights to this book and dedicated the book into the public domain. Terms available

here: <http://creativecommons.org/publicdomain/zero/1.0/>

About Google Books

Google's mission is to organize the world's information and to make it universally accessible and useful. Google Books helps readers discover the world's books while helping authors and publishers reach new audiences. You can search through the full text of this book on the web at <http://books.google.com/>

STIRLING ENGINES: A BEGINNERS GUIDE



VINEETH C S

STRILING ENGINES:

A BEGINNERS GUIDE

(REVISED VERSION-2012)

VINEETH C S

Copying and Reprinting:

Copying and Reprinting of this work is permitted with a view to make information accessible to all. Acknowledging this work wherever it is used will be appreciated.

Any further queries or mistakes you find in this work may be kindly addressed to vineethcs.cet@gmail.com .

*Dedicated to my parents,
Prof S. Chandran &
Dr. A.B. Suja*

- Tread where there is no path
and leave a trail.

FOREWORD

I have great pleasure to write a forward to the very fundamental book on Stirling Engines - A Beginners Guide, authored by Vineeth C S who completed his final year project under my guidance as a part of his B Tech degree course in Mechanical Engineering at College of Engineering Thiruvananthapuram. During initial phase of our discussion about the project work, I asked him to learn more about Stirling Engines which can be a source of Mechanical work output, derived from solar energy. The committed effort by Vineeth C S turns out to be the book on Stirling Engines - A Beginners Guide. I am personally proud of his venture because, to the best of my knowledge, Mr. Vineeth C S is the first Engineering college student in Kerala state who authored a book on a technical subject and the author deserves high level of appreciation for an outcome of this effort. I am certain that this book would provide a wealth of information to the students who desire to deepen their understanding about Stirling Engines. I hope that Mr. Vineeth C S, who is going to join at the Indian Institute of Science, Bangalore, for his higher studies, will continue his endeavor and the technical community will be benefited from similar kind of outcome. I wish him all success.

Happy reading to all

Dr. G Venugopal
Associate Professor
Department of Mechanical Engineering
College of Engineering
Thiruvananthapuram

PREFACE

During my final year, as I was working on my B.Tech project which involved the development of an efficient system which could utilize solar energy to produce work, I came across Striling Engines. Even though the concept was nearly two centuries old, there was very little development in the field, and even fewer literatures were available. Renewable energy systems will become the norm of the future and the knowledge of any systems that can aid developments in the field will assume prime importance. With this view in mind and the fact that our college libraries didn't have any exclusive book dealing with subject, I decided to write a book to spread awareness about the topic.

The book is primarily intended for new comers in the field who have little engineering knowledge. There a lot of pictures and links to various animated versions of the engine for making the concept clearer. Some of the explanations may seem unnecessary to a few readers, but please do keep in mind that this book is intended for beginners. For Advanced Readers a few technical papers and some foreign books by eminent scientists are listed at the end of the book.

I am extremely thankful to Dr. G Venugopal, Asst. Professor in Mechanical Engineering, my project guide, for his kindness to spare some of his precious time and taking pains to go through my book and write a suitable foreword for the same. I am grateful to my friend Rakesh R Mallan, for proof reading the book and suggesting useful reforms. I am indebted to my parents for their constant encouragement and support while I was working on the book. I am also thankful to all my friends for the love and support they extended. I am also thankful to all the websites and authors whose books, I referred during the preparation of the book (*All are mentioned in the Suggested Further Reference Section*).

In the end I would like to add that, in spite of taking all precautions to avoid misprints and factual errors, it is quite likely some might have crept in, and I will be much thankful to those who point out the same. Please feel free to contact me at vineethcs.cet@gmail.com with suggestions or comments to improve the book.

VINEETH C S

CONTENTS

1.	INTRODUCTION	1
2.	HISTORY	3
	2.1. ROBERT STIRLING	3
	2.2. PROFESSOR IVO KOLIN	5
	2.3. PROFESSOR JAMES SENFT	6
3.	THE STIRLING CYCLE	7
4.	THE BASIC STIRLING ENGINE	10
5.	PARTS OF A STIRLING ENGINE	13
	5.1. HEAT EXCHANGERS	13
	5.2. PISTON	13
	5.3. DISPLACER	14
	5.4. FLYWHEEL	15
	5.5. REGENERATOR	16
6.	TYPES OF STIRLING ENGINES	17
	6.1. ALPHA STIRLING ENGINE	19
	6.1.1. ROSS YOKE DRIVE FOR ALPHA STIRLING ENGINES	25
	6.2. DOUBLE ACTING TYPE STIRLING ENGINE	26
	6.3. BETA STIRLING ENGINE	30
	6.3.1. RHOMBIC DRIVE FOR BETA STIRLING ENGINES	37
	6.4. GAMMA STIRLING ENGINE	38
	6.5. LOW TEMPERATURE DIFFERENTIAL STIRLING ENGINES	44
	6.6. RINGBOM STIRLING ENGINES	46
	6.7. FREE PISTON STIRLING ENGINES	50
	6.7.1. FLUIDYNE ENGINE	55
	6.7.2. FLUIDYNE PUMP	57
	6.7.3. FREE PISTON ALTERNATOR STIRLING ENGINE	58
	6.8. MULTIPHASE STIRLING ENGINE	59
	6.9. ROTARY STIRLING ENGINE	61

7.	STIRLING CYROCOOLERS	62
	7.1. REVERSED STIRLING CYCLE	63
	7.2. DUPLEX STIRLING CYCLE	65
8.	PERFORMANCE OF STIRLING ENGINES	66
	8.1. STRENGTHS	66
	8.2. WEAKNESS	67
	8.3. PRESSURIZATION	68
	8.4. THE WORKING FLUID	70
	8.5. PRESSURE VARIATIONS INSIDE CYLINDERS	71
	8.6. TEMPERATURE VARIATIONS OF CYLINDERS	72
	8.7. BEALE NUMBER	73
	8.8. WEST NUMBER	73
9.	APPLICATION OF STIRLING ENGINES	75
	9.1. SOLAR BASED POWER GENERATION	75
	9.2. SOLAR THERMAL PUMPING SYSTEM	76
	9.3. STIRLING ENGINES IN AUTOMOBILES	77
	9.4. CHIP COOLING	78
	9.5. TOP USES OF STIRLING ENGINE IN HISTORY	79
10.	HOW TO MAKE A STIRLING ENGINE MODEL	80
	10.1. TEST TUBE STIRLING ENGINE	80
	10.2. TWO CAN STIRLING ENGINE	84
11.	HOW DO I MAKE A REAL STIRLING ENGINE?	93
12.	SUGGESTED FURTHER REFFERENCE	95

INTRODUCTION

The Stirling engine is an external combustion, closed, cyclic heat engine which works on the Stirling Cycle. A typical Stirling engine consists of two zones which are maintained at different temperatures and a working fluid is shuttled between these regions to extract work. Unlike the conventional engines and steam engines (an external combustion engine), there are no valves and the working fluid never leaves the engine and is used over and over again. The working fluids commonly used are air, hydrogen or helium.

Why Stirling engines? You might be wondering why there is much fuss about these engines and yet why so little development has taken place. The greatest attraction this engine offers an engineer is the fact that theoretically it can achieve "CARNOT EFFICIENCY". The only other cycle that can achieve Carnot efficiency other than the Stirling cycle is the Ericson cycle. More over cleaner energy sources will soon become the norm and the Stirling engine will definitely play a huge role in the revolution due to its flexibility in the way heat can be supplied to the engine. Be it solar energy, geothermal or even a pile of burning garbage can power the engine. The numerous advantages of the engine will be discussed in the coming chapters.

Even though opportunities are so huge yet very few researches have been done in this field. The most popular argument is that we can never make an engine that can match the power of a conventional IC engine of the same size. That may be true, but then if we look around we can see many similar situations. If the turbojet or turbofan is the ultimate airline propulsion system, then why should aircrafts be fitted with turboprop engines? The simple fact exists that turboprops outdo turbojets when it comes to short take offs and they provide improved lift at low speeds. If Stirling engines can't beat conventional engines at larger scales they are definitely doing much better in smaller scales. Micro-Star International

Co., Ltd (MSI), Taiwan, recently developed a miniature Stirling engine cooling system for personal computer chips that uses the waste heat from the chip to drive a fan. Surely with more focused research and innovations it is definitely possible to come up with a lot more exciting possibilities in this field.

"...These imperfections have been in great measure removed by time and especially by the genius of the distinguished Bessemer. If Bessemer iron or steel had been known thirty five or forty years ago there is scarce a doubt that the air engine would have been a great success... It remains for some skilled and ambitious mechanist in a future age to repeat it under favorable circumstances and with complete success...."

- Rev'd Dr. Robert Stirling, 1876
from "Stirling Engines" by G. Walker

HISTORY

The history of the Stirling engine dates back to the year 1807, when Sir George Cayley (1773 – 1857) published in England the construction drawing and description of a machine he called the “caloric machine”. This machine stayed on the drawing board and wasn’t realized . But this idea stimulated a lot of engineers to follow up the idea and to improve it.

ROBERT STIRLING:

On September 27, 1816, at the age of 26, Church of Scotland minister Robert Stirling applied for a patent for his economizer in Edinburgh, Scotland. The device was in the form of an inverted beam engine (a type of steam engine where a pivoted overhead beam is used to apply the force from a vertical piston connected to a vertical connecting rod), and incorporated the characteristic phase difference between the displacer and piston that we see in all Stirling Engines today. The inverted beam setup can be seen in Fig(3).The engine also featured the cyclic heating and cooling of the internal gas by means of an external heat source, but the device was not yet known as a Stirling Engine. That name was coined nearly one hundred years later by Dutch engineer Rolf Meijer to describe all types of closed cycle regenerative gas engines.

The patent also described in detail, the use of one form of economizer that is now known as the regenerator. It was undoubtedly one of Robert Stirling most important inventions, which went on to become part of many other cyclic air engines especially those developed by Ericsson. In the 1820's Robert was joined by his younger brother James, whose major contribution was to suggest pressurizing the internal gas to increase the power output. Further improved design patents were applied for in 1827 and 1840.

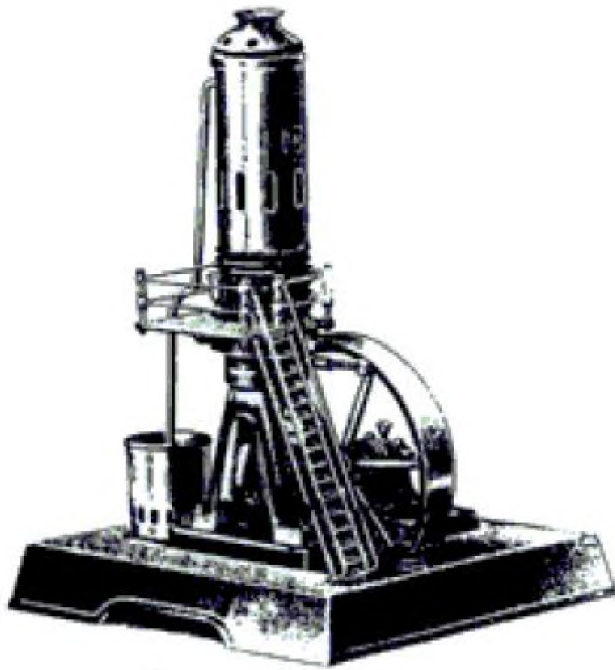

Fig (1): Model of a Stirling Engine made by Robert Stirling

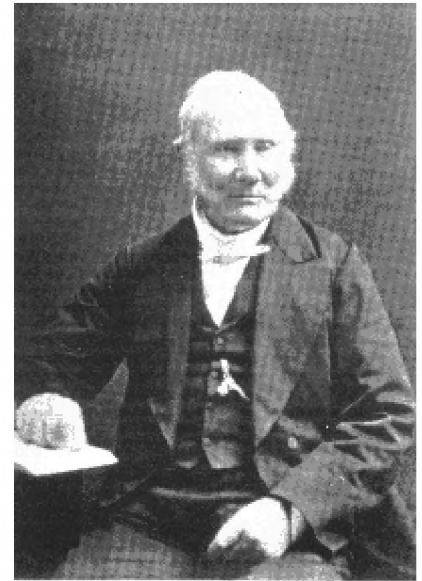

Fig (2): Robert Stirling

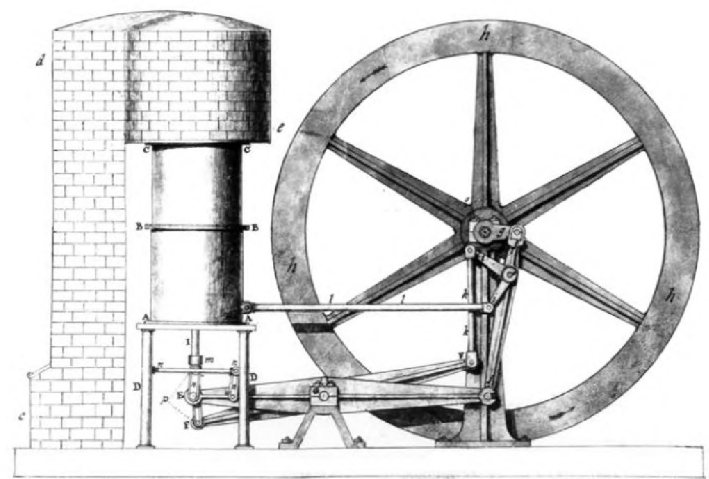
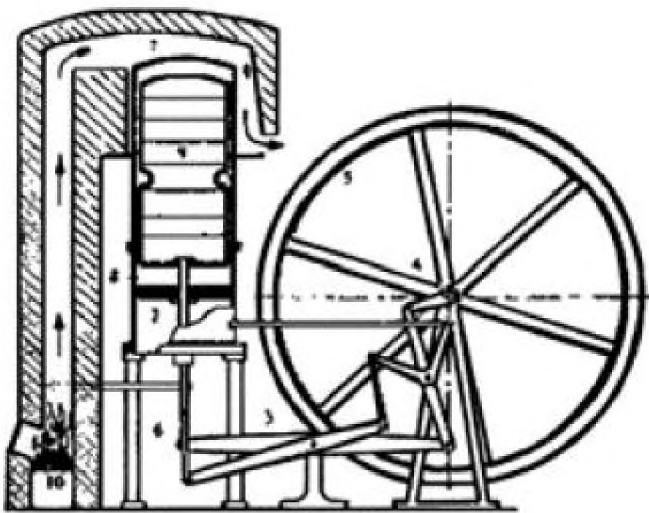

Fig (3): Drawings made by Robert Stirling for his patent in 1816*

**Refer Suggested Further Reference Section for a link to the animated version of the engine.*

PROFESSOR IVO KOLIN



Fig (4): Professor Ivo Kolin

Early in 1983, Professor Ivo Kolin of the University of Zagreb, Croatia, demonstrated the very first low temperature differential Stirling engine to an amazed audience. This engine ran on a temperature difference of 100°C , which at the time was an astonishingly low figure. The demonstrated engine ran for a long time as the temperature difference was lowered, eventually stopping when the difference dropped below 20°C .

This feat was all the more remarkable when you consider the engine was constructed entirely with hand tools. The engine had no power piston and cylinder, instead relying on a rubber diaphragm to transmit the power from the square main chamber. A feature of this engine was the 'slip-link', a device for imparting an intermittent motion to the displacer inside the main chamber. At the low speed that this engine ran at, a dwell at each end of the displacer stroke was very beneficial. During the 1980's, Professor Kolin continued to refine his low temperature engines, still relying on a diaphragm but simplifying the original complex displacer drive mechanisms.

PROFFESOR JAMES R SENFT

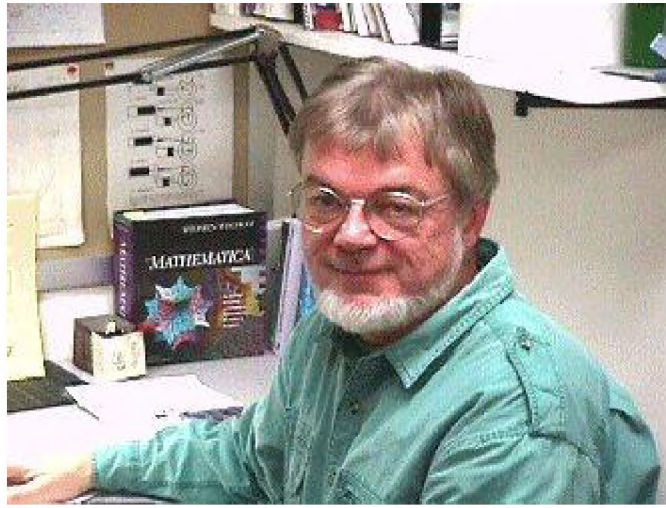

Fig (5): Professor James R Senft

During the late 1980's and the early 1990's Professor Senft of the University of Wisconsin took up the idea of low temperature differential Stirling engines. The first models he produced were Ringbom engines, where there is no direct connection between the flywheel and the displacer, the Ringbom engine is reliant on the changing pressure inside the main chamber to move the displacer back and forth. Professor Senft, working closely with Professor Kolin, continued working with Stirling engines, working out many of the design solutions that are used today in low temperature differential Stirling engines.

In 1992 Professor Senft was asked to design and build a low temperature differential engine for NASA. This engine, called the N-92, was optimized for hand held operation, with a temperature difference as low as 6°C enough to power it. The model MM-7, Fig(30), another “heat of the hand” engine designed by Professor Senft has become extremely popular and is widely used for demonstrations. Professor Senft continues to work with Stirling Engines, and has written several books detailing the history and manufacture of Stirling engines

THE STIRLING CYCLE

The first step in understanding how the Stirling engine works is to know what the Stirling cycle is. The cycle consisting of two isochoric (constant volume) and two isothermal processes is one of only two cycles theoretically capable of achieving Carnot efficiency.

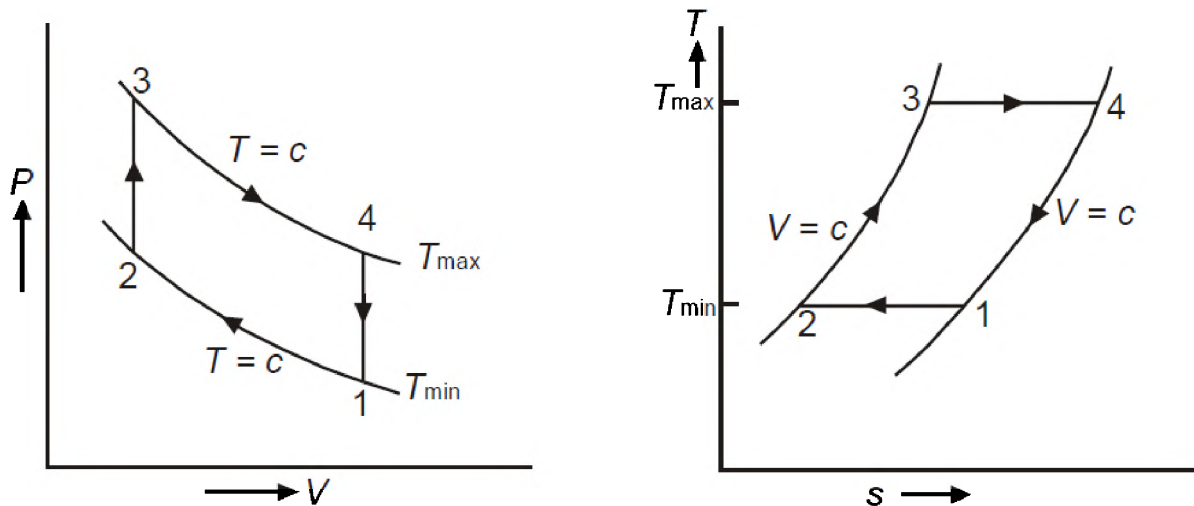

Fig (6): The ideal Stirling Cycle in PV and TS diagrams

Process 1-2: Isothermal compression and heat rejection.

The working fluid in the cold side is compressed isothermally by keeping it in contact with the low temperature reservoir. The work required for this stroke is supplied by the piston, utilizing the inertia of the flywheel.

Process 2-3: Isochoric heat addition.

The working fluid comes in contact with regenerator, which transfers heat to the working fluid and raises its temperature to T_{\max} . This process also raises the pressure and entropy of the working fluid.

Process 3-4: Isothermal expansion and heat addition.

The working fluid comes in contact with the high temperature reservoir and expands isothermally doing work. This is the power stroke of the engine. All the heat added is converted to work, as it is an isothermal process.

Process 4-1: Isochoric heat rejection.

The working fluid comes in contact with the regenerator which is now at a lower temperature (T_{\min}) and rejects heats at constant volume before moving to the cold cylinder. The pressure and entropy of the working fluid is reduced.

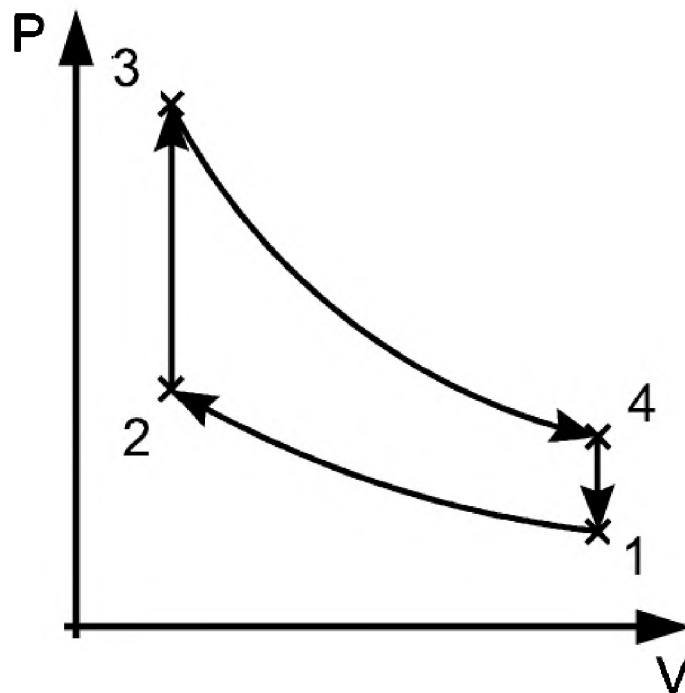

Fig (7): The practical Stirling cycle, with imperfect regenerator.

When the regenerator is not 100% efficient, the regenerator does not give back all the heat it absorbs in 4-1 to the working fluid at 2-3. This requires additional external energy to be supplied to the gas so as to make its temperature equal to that of the hot reservoir. This decreases the overall efficiency of the system. Hence only with a 100% efficient regenerator is it possible to achieve Carnot efficiency.

Mathematical Proof:

Consider a regenerator with efficiency ξ

Process 3-4-> Heat supplied to the working fluid: $mR T_{max} \ln \frac{V_4}{V_3}$

Process 4-1 -> Heat rejected to regenerator: $m C_v (T_{max} - T_{min})$

Process 1-2-> Heat rejected to cold reservoir: $mR T_{max} \ln \frac{V_1}{V_2}$

Process 2-3->Heat absorbed from regenerator: $\xi m C_v (T_{max} - T_{min})$

(since the regenerator is not 100% efficient)

Since $\xi < 1$, excess heat energy equal to $(1 - \xi) m C_v (T_{max} - T_{min})$ has to be supplied to the working fluid to raise its temperature to T_{max} .

Hence the total heat supplied to the gas in a cycle is equal to:

$$mR T_{max} \ln \frac{V_4}{V_3} + (1 - \xi) m C_v (T_{max} - T_{min})$$

The work done is equal to the difference in the heat absorbed in process 3-4 and that rejected in 1-2, which is equal to:

$$mR \ln r (T_{max} - T_{min})$$

$$\text{(where } r = \frac{V_4}{V_3} = \frac{V_1}{V_2}\text{)}$$

Hence the efficiency of the cycle is given as:

$$\epsilon = \frac{mR \ln r (T_{max} - T_{min})}{mR T_{max} \ln r + (1 - \xi) m C_v (T_{max} - T_{min})}$$

We can clearly see if $\xi=1$ then the equation reduces to the efficiency of the Carnot engine.

$$\epsilon_{\xi=1} = 1 - \frac{T_{min}}{T_{max}}$$

THE BASIC STIRLING ENGINE

Let us consider a theoretical single cylinder Stirling engine to understand how the above cycle is implemented in a Stirling engine. In the engine we consider the cylinder will be brought in contact with the source, sink and the regenerator as and when required to realize the cycle. Note that the thick black lines show the insulation and thin black lines indicate that the cylinder is in contact with the adjoining reservoir.

Process 1-2: Isothermal heat rejection and Compression

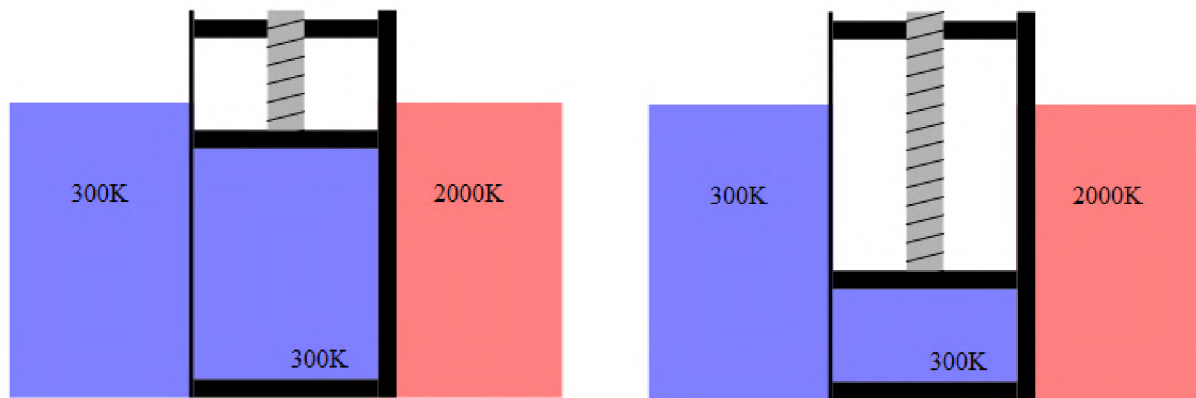

(i) At the start of compression

(ii) At the end of compression

The cylinder is in contact with the cold reservoir when the gas is being compressed and this makes the compression isothermal and for this to be practical the process should be very slow. Hence practically the process is not isothermal. The thick black line shows the working fluid is insulated from the hot reservoir.

Process 2-3: Isochoric heat addition:

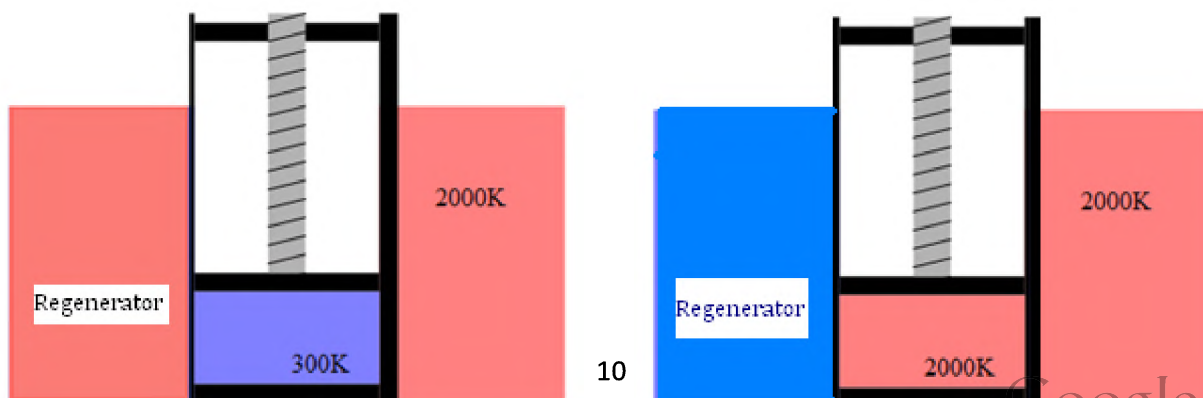

The working fluid now comes in contact with the regenerator which should have the temperature of the hot reservoir, if it were 100% efficient. Let us assume it is 100% efficient and that it raises the temperature of the working fluid to the temperature of hot reservoir. In all practical cases the regenerator becomes a wire mesh or a metal honeycomb through which the working fluid passes.

Process 2-3 Isothermal heat addition and expansion

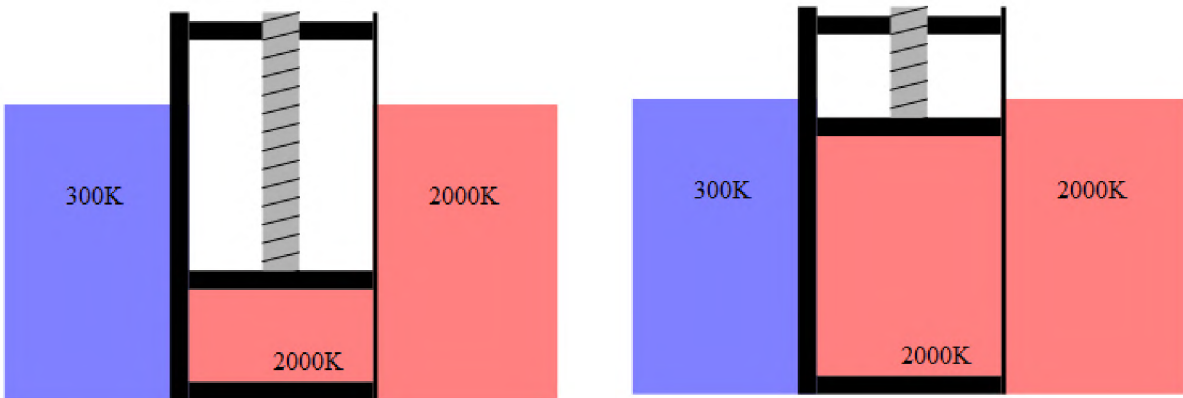

(i) At the start of expansion

(ii) At the end of expansion

The working fluid is now made to come in contact with the hot reservoir. The gas expands while it is in contact with hot reservoir doing work. This is the power stroke of the engine. Work required for the compression stroke is derived from the energy stored in the flywheel during the power stroke.

Process 3-4 Isochoric heat rejection

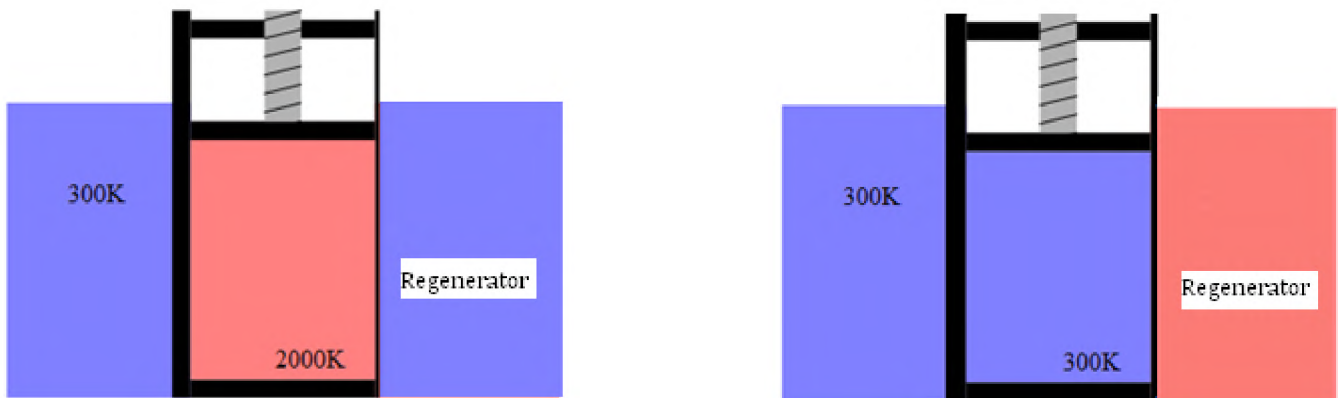

The working fluid now comes in contact with the regenerator and rejects heat to it as the working fluid is now hot compared to the regenerator. This makes the temperature of the working fluid equal to that of the cold reservoir and the cycle continues.

PRINCIPLES INVOLVED

- The working fluid is a gas operating under relatively high temperatures and obeys the gas laws. When the gas is heated and because it is in a sealed chamber, the pressure rises and the force due to its pressure acts on the power piston to produce a power stroke.
- When the gas is cooled the pressure drops and this means that less work needs to be done by the piston to compress the gas on the return stroke, giving a net gain in power available on the shaft.
- The efficiency of any Thermodynamic cycle increases as the average temperature of heat addition increases. Regenerators are used for this purpose.

PARTS OF A STIRLING ENGINE

1. HEAT EXCHANGERS:

One cylinder of the Stirling engine has to be maintained at a high temperature while the other end has to be maintained at a low temperature. Heat exchangers are used to achieve this. They are as their name suggests devices that help in exchanging heat from one medium to another. At the hot end the heat from a source is transferred to the cylinder, while at the cold end the heat from the cylinder has to be transferred to the atmosphere. Those Stirling engines that are directly heated do not have significant heat exchangers. Air cooled Stirling engines usually have simple heat exchangers while there are water cooled Stirling engines which have more complex heat exchangers.

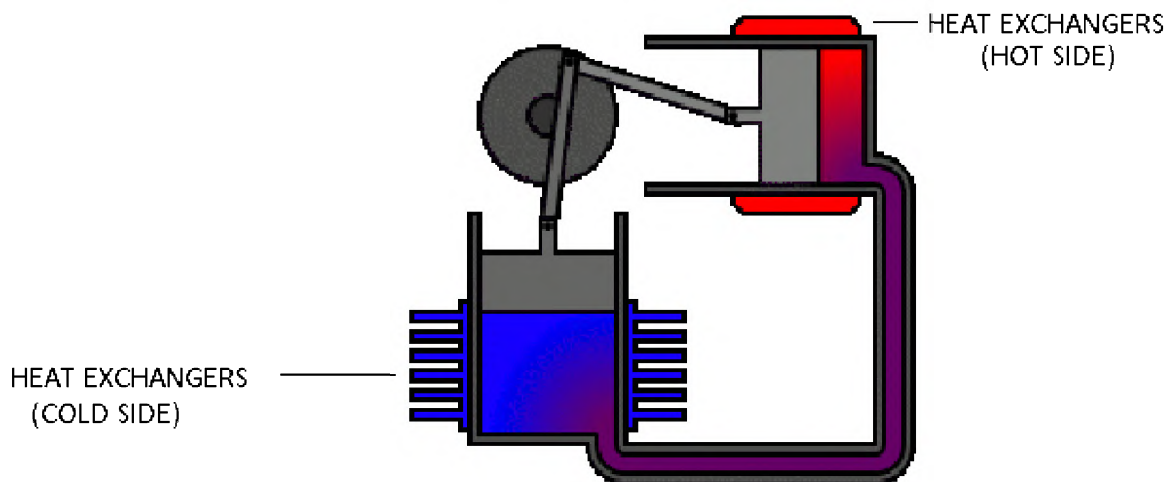

Fig(8): An Alpha Stirling engine showing the heat exchangers

2. PISTON:

A piston is a sliding member which can move from the one extreme end of the cylinder to the other extreme end, commonly referred to as the dead centers. Typically the movement of the piston varies the volume inside the cylinder since the working fluid does not escape through the clearance between the piston and the cylinder interface. The piston of the Stirling

engine is identical to one present in the engine of an automobile. It is the gas pressure acting on the piston, which is derived as the work output of the engine.

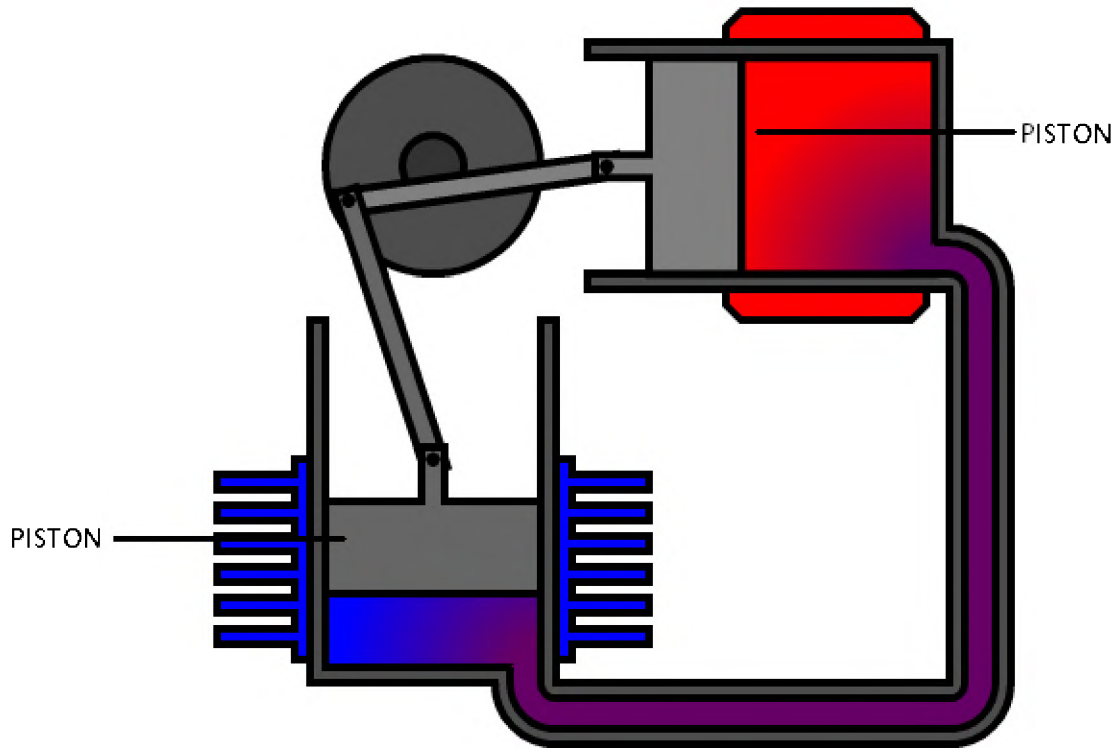

Fig(9) An Alpha Engine showing its pistons. Note that there is no clearance at the piston cylinder interface.

3. DISPLACER:

A displacer is a sliding member which resembles a piston but the clearance between the displacer and the cylinder is much larger. This allows for the working fluid to pass easily through the clearance. Since as we can visualize, the movement of the displacer doesn't compress the gas or causes it to expand, hence the movement of a displacer never varies the volume of the cylinder. Gas pressure forces acting on the displacer will be negligible compared to that on the piston as most of the gas escapes through the clearance to the low pressure side.

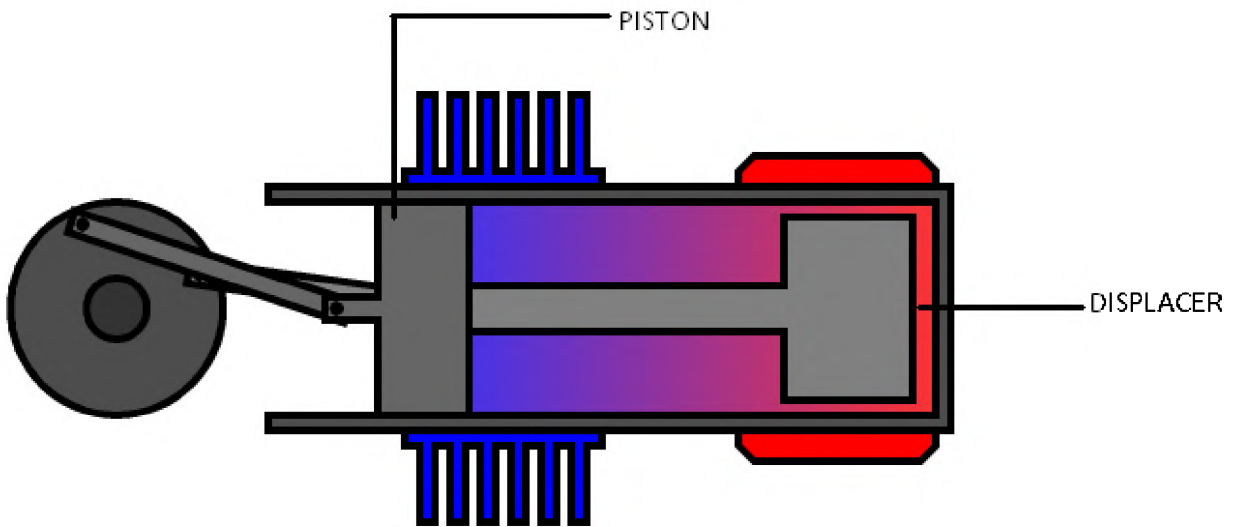

Fig(10): A Beta Stirling engine showing its piston and displacer. Note the difference in the clearance.

4. FLYWHEEL:

The flywheel is an inertial mass, to which the piston and the displacer (if present) is coupled. As we know there is only one power stroke and during this stroke the flywheel stores some energy as rotational kinetic energy, consequently the speed of the flywheel increases. Now during all other strokes the energy from the flywheel is used up and its speed comes down. The flywheel thus reduces the fluctuation of the engine speed and also provides power for the other strokes. The power output of the engine is taken out through the flywheel, meaning a suitable mechanism is coupled to the flywheel to utilize the work produced. Some type of Stirling engines do not have any flywheel.

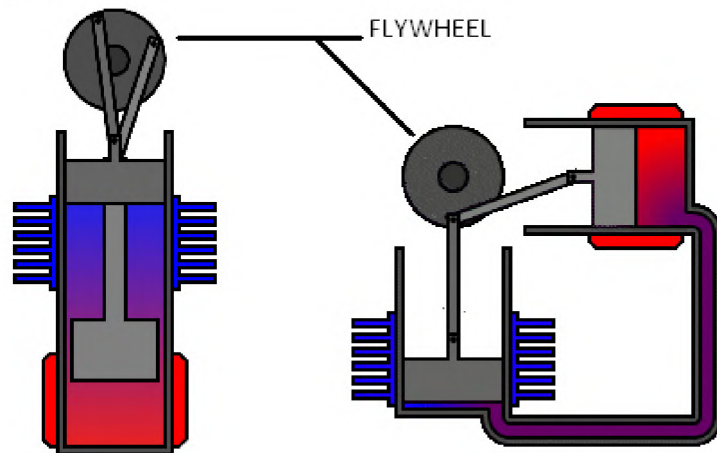

Fig(11): Alpha and Beta Stirling engine showing their flywheels.

5. REGENERATOR

The regenerator is one of the most important parts of a Stirling engine. It is basically nothing but a heat exchanger. For most common heat exchangers the direction of heat flow is constant or unidirectional, i.e. the cold and hot fluids always flow in a fixed direction and the flow is continuous. But in case of a regenerator the flow of heat is intermittent. When the regenerator is cold, the hot fluid is passed over it. This heats up the regenerator and cools the hot fluid. Subsequently the cold fluid is passed over the regenerator which is now at a higher temperature and heat is now transferred from the regenerator to the fluid.

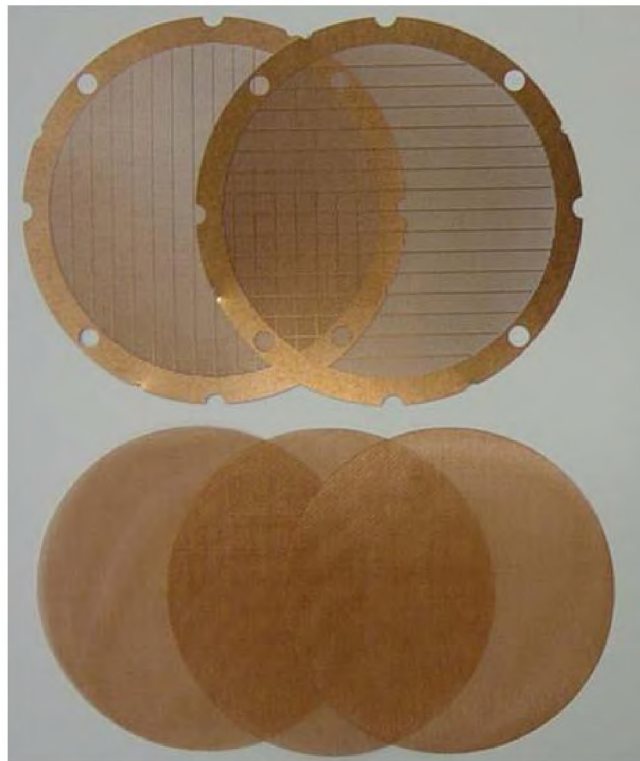

Fig(12): Regenerators used in the Multiphase Stirling Engine.

Regenerators are usually simple devices like woven copper screens which are stacked inside the passage that connects the hot and cold cylinder. Even the walls of the passage can act as a regenerator in the absence of these, but it won't be that efficient. A very good regenerator should not offer too much resistance to the flow of working fluid, else the efficiency of the engine will fall as a lot of work will be used up in moving the working fluid.

TYPES OF STIRLING ENGINES

Since the Stirling engine works on a closed cycle, it is not possible to reject heat as in other engines where the working fluid is merely exhausted. This requires the engine to have two zones (the cold and hot zone) usually separated by the regenerator. The most common classification is based on how the working fluid is moved between the two zones (the first two main types). Stirling engines are also classified based on whether they have mechanical linkages to a flywheel or not. Some of the types of Stirling engines are:

1. Piston type

These make use of the piston to move the working fluid from the hot end to the cold end and vice-versa.

(i) Alpha Stirling engine:

Here there are two separate pistons and cylinders. The working fluid is shuttled between these cylinders via a passage containing the regenerator. Both the pistons are connected to a single flywheel and usually at the same point.

(ii) Double Acting type Stirling Engine:

In Double Acting type Stirling Engine, either side of the piston is in contact with the working fluid. Usually four such pistons are arranged together, and a suitable mechanism (other than a flywheel) is used to maintain the phase difference.

2. Displacement type Stirling engine:

These have one power piston and a displacer. The displacer differs from the piston in the fact that it has a larger clearance and allows the working fluid to pass through the clearance and doesn't extract work. They can further be classified as:

(i) Beta Stirling Engine:

The Beta Stirling engine has a displacer and piston mounted in a single cylinder. The piston and the displacer are nearly of the same size and are connected to a single flywheel at different points with a calculated phase difference.

(ii) Gamma Stirling engine:

The Gamma Stirling engine has a larger displacer and the power piston is mounted in a separate cylinder. The displacer and piston are connected to a shaft at different places and this shaft is connected to the flywheel.

(iii) Ringbom Stirling engine:

These are identical to Gamma Stirling engines except for the fact that the displacer is not mechanically linked to the power piston. Instead the displacer is made a bit larger and its motion is due to the resultant force acting on it due to the gas pressure.

(iv) Delta Stirling engine*

A proposed configuration, which has a displacer like a Gamma Stirling engine, but has two pistons, one for the hot side and the other for the cold side.

3. Free piston Stirling engines:

These are Stirling engines with non rigid pistons like the liquid piston and the diaphragm. The number of mechanical linkages required is reduced and the produced work is extracted using a linear motor or a pump. The number of moving parts is reduced and hence friction and wear will be lower.

4. Rotary Stirling Engine:

These are Stirling engines that convert the work from the Stirling cycle directly into torque. They can be thought of as similar to the Wankel engine. Only experimental prototypes exist.

ALPHA STIRLING ENGINE

The Alpha Stirling engine is the simplest Stirling engine and it consists of two working pistons and two cylinders connected via a regenerator. Both the cylinders are connected to a single flywheel and are usually aligned at 90° to each other. The hot piston is located near the high temperature heat exchanger while the cold piston is in contact with the low temperature reservoir, which in many practical cases is the atmosphere. The two pistons are connected to the flywheel in such a way that the linear translatory motion can be converted into rotary motion and the phase difference can be maintained. In most cases they are joined at a common point in the flywheel to achieve this.

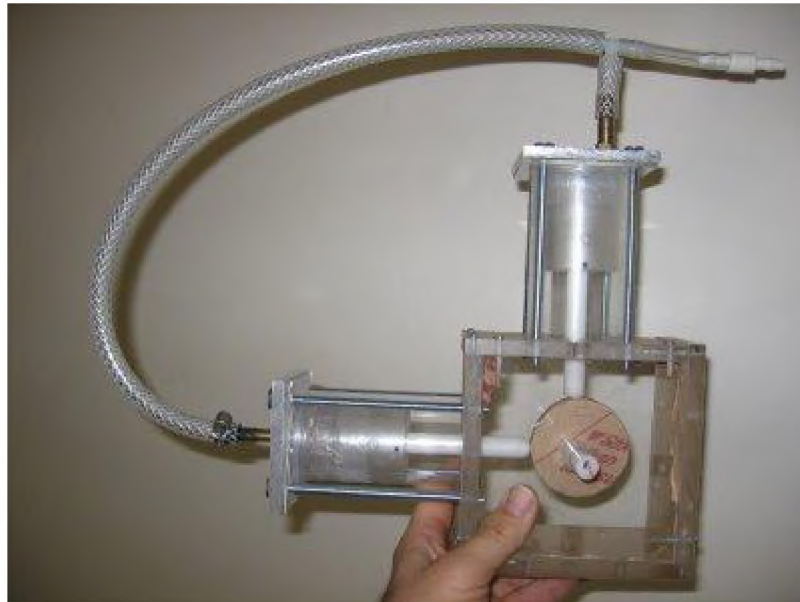

Fig(13): An Alpha Stirling engine. Note the plastic tube contains the regenerator.

Compared to the other basic types of Stirling engines the power developed for a given volume is highest in case of Alpha engines. This is because higher compression ratios can be obtained in an Alpha type Stirling engine compared to other types of Stirling engines.

WORKING:

Let's see how the engine practically executes the Stirling cycle. For understanding this we can break the working of a Stirling engine into four operations similar to that of Petrol or Diesel Engine. The only difference will be that the addition and rejection of heat will be based on the Stirling cycle while that of the other two engines are based on the Otto and Diesel cycles respectively. Understanding the working of any practical Stirling engine is challenging as every process executed by a Stirling engine is due to the combined action of the two or more pistons/displacers. For an Alpha Stirling engine there are two pistons and hence motions of both the pistons have to be visualized while trying to understand the working of this engine.

1. Transfer of working fluid from cold side to hot side:

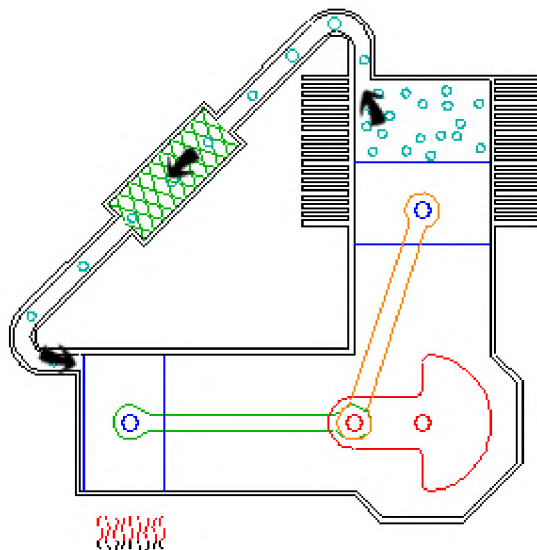

At the moment shown in the picture, the flywheel is moving clockwise, the hot piston (the one that is heated) is moving right to the Outer Dead Centre (ODC) and the cold piston (the one with cooling coils) is moving up towards the Top Dead Centre (TDC). The criss-cross section in the passage connecting both the cylinders shows the regenerator. The regenerator is comparatively hot at this stage.

Now visualize the Stirling cycle, note how the working fluid flows through the regenerator and how Process 2-3 (Constant Volume Heat Addition) is practically achieved. The motion of the pistons is in such a way that the change in the engine volume is minimum (while one piston moves up reducing the engine volume the other moves out increasing the volume) and heat addition can be approximated to be at constant volume. At the end of this process, the working fluid will be warmer and majority of it will be in the hot cylinder.

As a crude analogy the process can be compared to a petrol engines suction stroke.

2. Expansion or Power stroke:

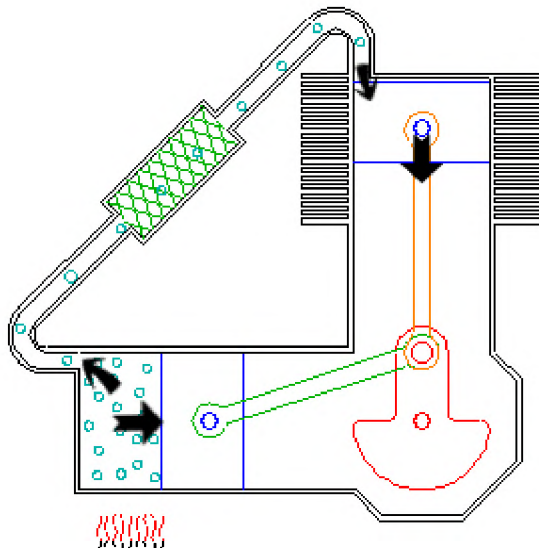

The flywheel has turned 90° and majority of the working fluid is now in the hot cylinder. At this stage the volume of the engine is minimum. The fluid now gets heated from the high temperature source (any practical heat source). The working fluid expands as it takes in heat and does work on the piston, moving the flywheel further clockwise. This is the power stroke of the engine and all other strokes utilize the energy from this stroke.

Note the arrows. As the hot piston is being moved right due to gas pressure, the cold piston too starts moving from TDC to Bottom Dead Centre (BDC). As the gas

is expanding a small portion of it is already moving to the cold piston through the regenerator.

As far as the Stirling cycle is concerned, we are on process 3-4 (Isothermal heat addition). As the heat added to the system is immediately converted to work, there is very little rise in temperature and the process can be closely approximated as an Isothermal process. Practically perfect isothermal processes are attained only through phase change process, the likes of which cannot be employed here.

This can be compared to the power stroke of the petrol engine, we visualized earlier. External heat addition powers a Stirling engine, whereas internal chemical reactions power a petrol engine.

3. Transfer of working fluid from hot side to cold side:

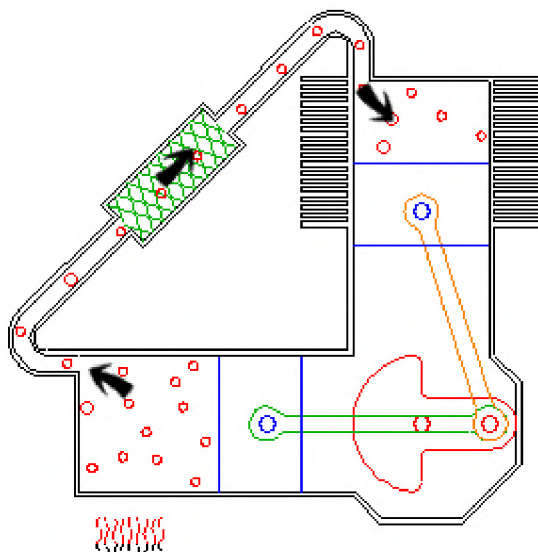

The working fluid has expanded to about three times its volume at the start of power stroke. The flywheel has turned through another 90° (or 180° since the start) and the hot piston has reached its ODC and is starting to move to the Inner Dead Centre (IDC). The cold piston is still moving downwards. The regenerator that was cold at the start of the stroke is now getting heated up as the hot working fluid passes through it.

We have now reached process 4-1 (Constant Volume heat rejection) on the Stirling cycle. The reason why this can be approximated as a Constant volume process can be reasoned in a similar way as we did with the other process.

This can be compared to the exhaust stroke of a petrol engine.

4. Compression Stroke:

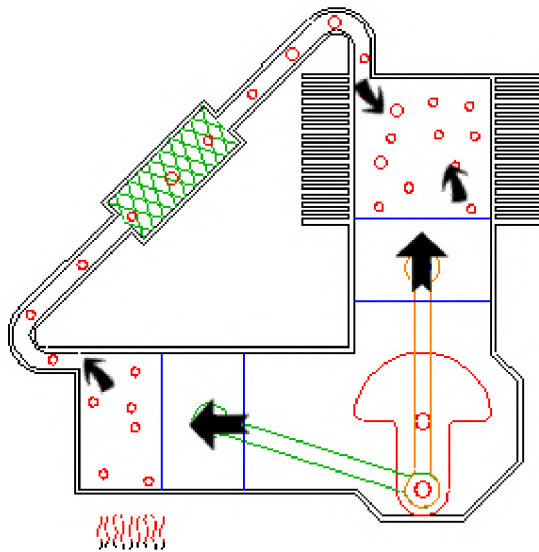

The crank has turned through another 90° (270° since the start). The cold piston is at the BDC and the hot piston is moving right to the IDC. The majority of the working fluid is in the cold cylinder and starts to cool down, exchanging heat with the cold reservoir. As the cycle proceeds the cold piston moves to the TDC (with the hot piston moving to IDC). This reduces the effective volume inside the engine and the working fluid is compressed inside the cold cylinder.

On the Stirling cycle we have reached the process 1-2 (Isothermal Compression). Since the gas rejects heat at the same time it is compressed, the temperature of the working fluid remains nearly constant. (The work done on the working fluid is immediately rejected as heat and so there is not much change in the internal energy of the fluid and hence negligible temperature change

occurs). Since compression is near isothermal, the work expended is also minimum.

At the end of the process almost all the gas would be in the cold piston and the volume of the working fluid would be reduced to nearly one-third of its volume after expansion. The state at the end of this process will be the same as that we started with initially and the cycle repeats. The flywheel inertia powers all the strokes after the power stroke.

This last stroke would be difficult to compare to that of a petrol engine as it is an open cycle engine. Loosely we may compare this to a supercharger or turbocharger pre-compressing the air before it enters into the cylinder. Unlike a petrol engine there is no compression inside the power piston of a Stirling engine.

You might have wondered why the working fluid is not shown as red bubbles (meaning they are hot) after it passes through the regenerator in the very first stroke that we came across. It is because the regenerators are not very efficient in actual cases and the working fluid becomes comparatively hot only after it enters the hot cylinder. Same is the reason for the red bubbles in the cold cylinder instead of green ones.

For Animation visit - <http://www.animatedengines.com/vstirling.shtml>

ROSS YOKE DRIVE FOR ALPHA STIRLING ENGINES

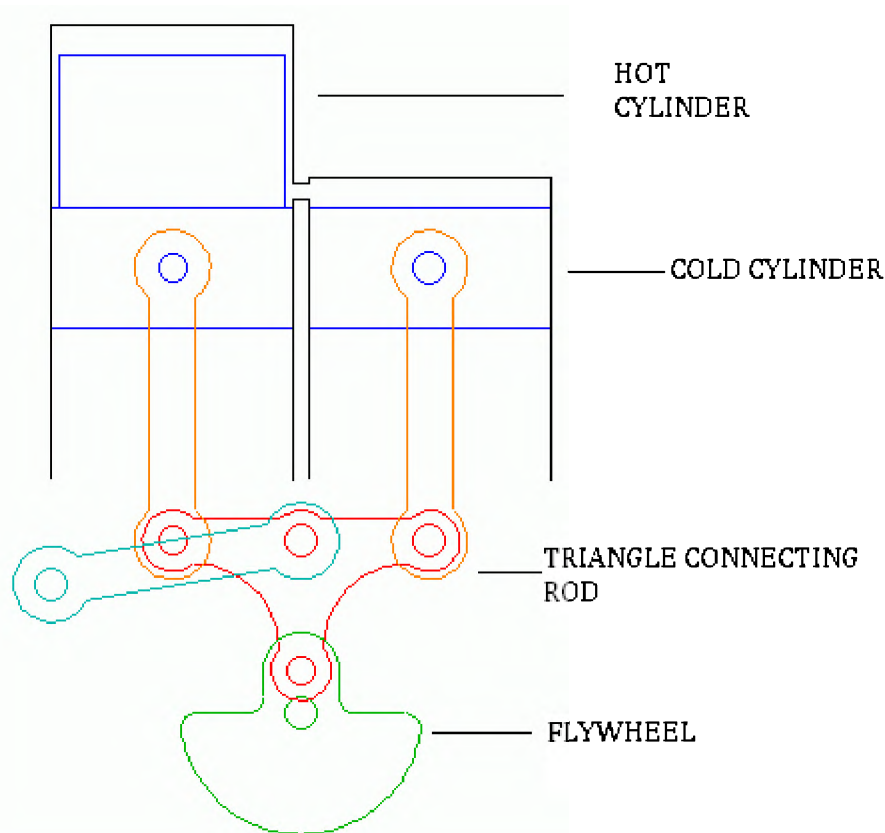

Fig(14): An Alpha Stirling engine with a Ross Yoke drive*.

The Ross yoke drive, was first incorporated into Stirling engines by Andy Ross of Ohio, a prominent Stirling Engine experimenter and hence the name. Even though a claim exists that Andy invented this linkage, it is said that similar linkages were used for over 200 years in steam engines.

The use of this linkage makes the Stirling engine a lot more compact. Moreover the connecting rods travel in more or less a straight line. This reduces the side thrust on the pistons and thus the performance of the engine is improved as more power is available at the flywheel. Moreover, less side thrust means less wear due to friction and life is also improved. Regenerators can be employed in the passage connecting the cylinders.

For animation visit - <http://www.animatedengines.com/ross.shtml>

DOUBLE ACTING TYPE STIRLING ENGINE

The double acting type Stirling engine is a variant of the piston type Alpha Stirling engine, usually having four cylinders. The pistons are double acting meaning, they act as the expansion piston of one engine and also the compression piston of a neighbouring engine. This makes the four cylinder set-up equivalent to an arrangement of four Alpha engines. Sir William Siemens is credited with the invention of the double acting type Stirling engine.

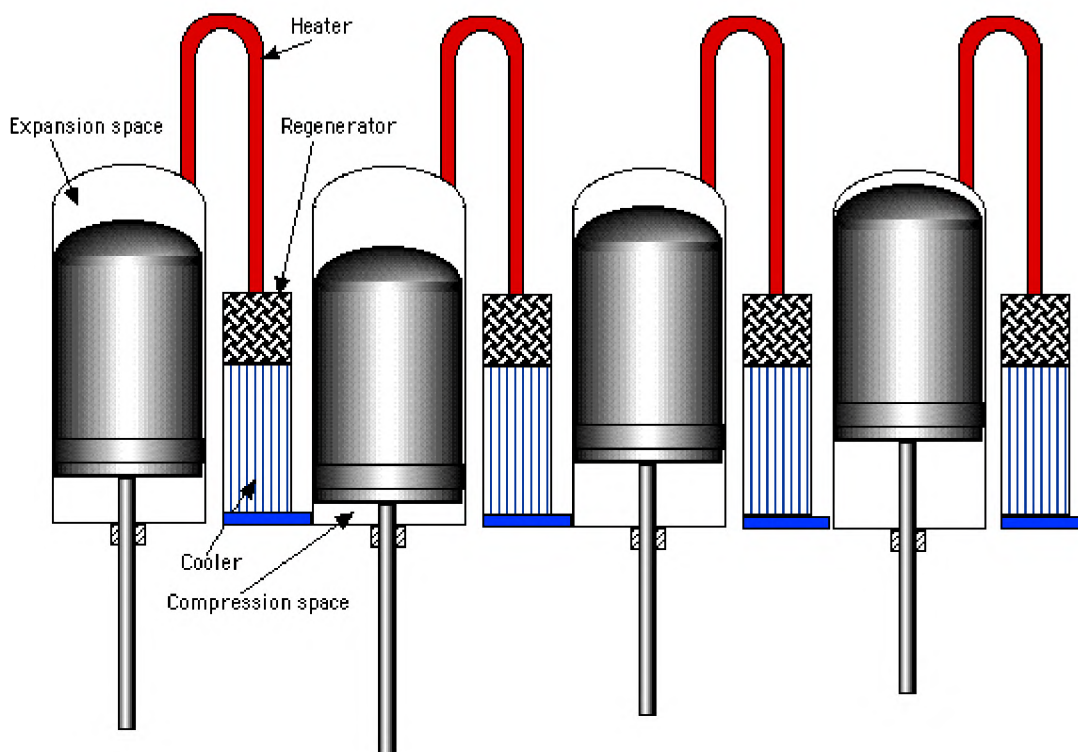

Fig(15): A schematic of a Double acting type Stirling engine.

The cylinders are usually arranged in a circular fashion with the neighbouring cylinders having their cold and hot regions connected through a passage containing a reservoir. Hence the outlet from the last cylinder in the picture will be connected to the first cylinder. This arrangement makes the engine a lot more compact and enables it to have a very high specific power output. All the pistons operate at a 90° phase difference with each other.

The biggest problem associated with this engine is the difficulty in designing a mechanism to harness the power developed by the pistons, at the same time maintaining the required phase difference between the pistons. A number of mechanisms have been made for the purpose, like the Rocking yoke mechanism, Swash plate mechanism and a gear mechanism.

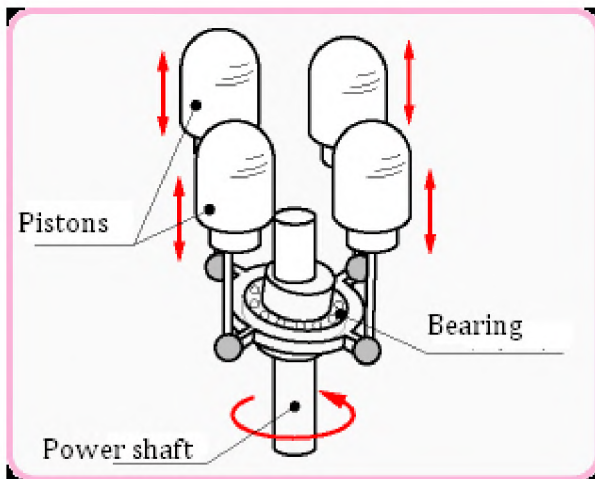

Fig(16):Concept Rocking yoke

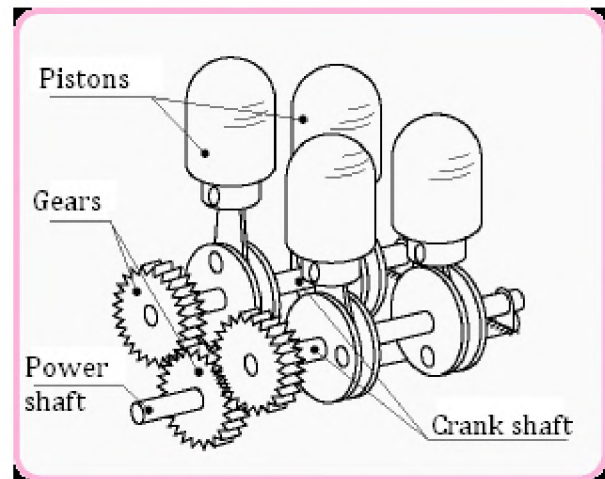

Fig(17):Gear mechanism

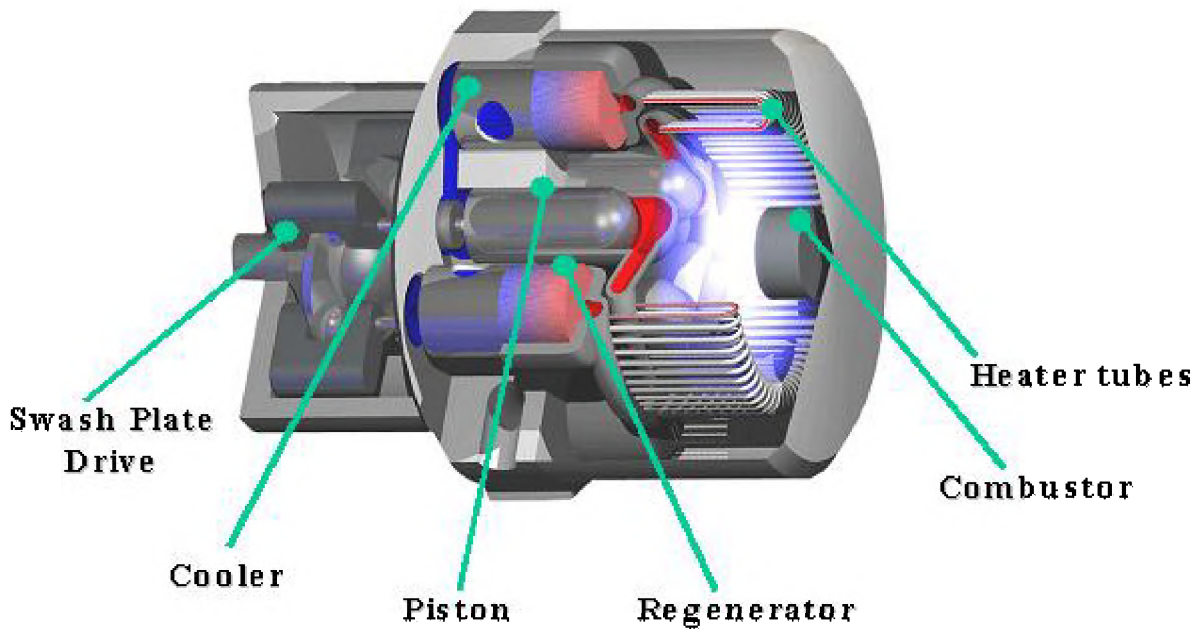

Fig(18):A double acting type Stirling engine using a Swash plate mechanism*

All the above mechanisms though in use are riddled with problems due to excess wear and they have low reliability. Excessive side thrust is produced in these mechanisms and hence life of the engine is considerably lower. William Beale of Sunpower Inc., came up with a new configuration which eliminated most of these problems by using a turbine through which the power out of the engine is harnessed.

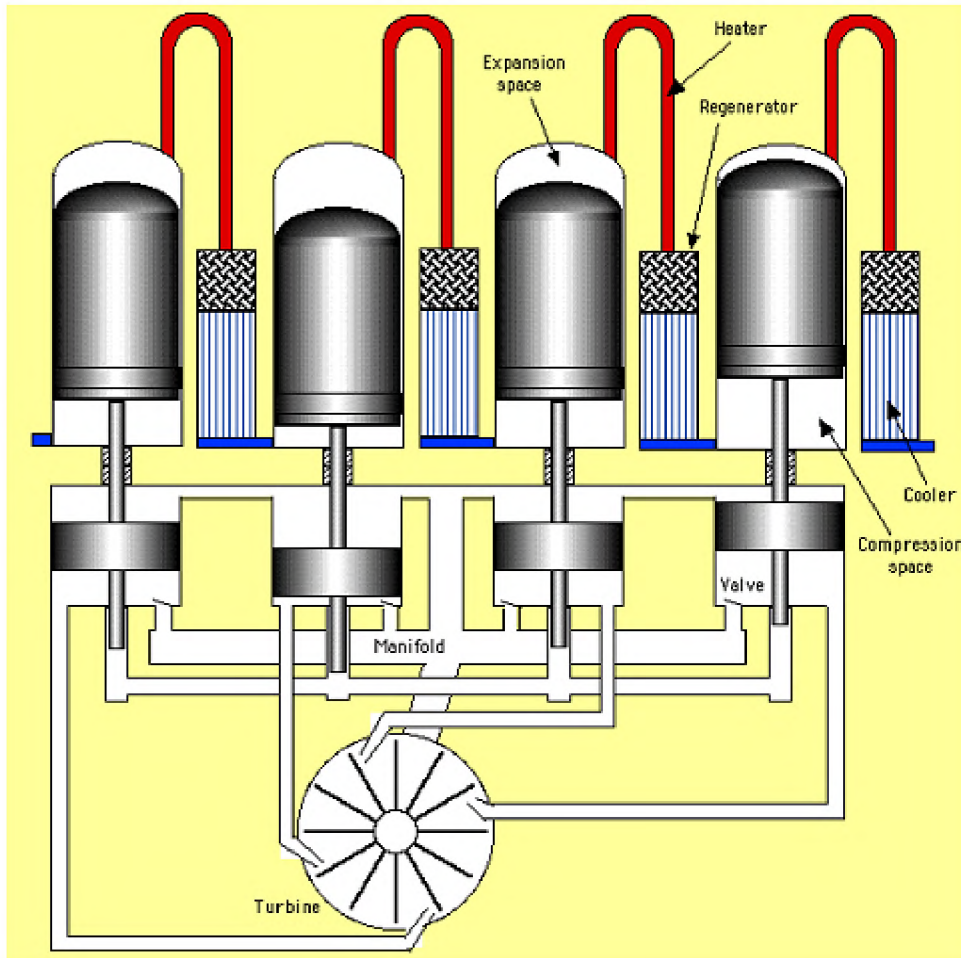

Fig(19): Mechanism designed by William Beale

This mechanism shown in figure uses single acting gas compressors (those pistons connected to the pistons of the Stirling engine) driven by the pistons to power the turbine. For better efficiency double acting gas compressors are used so that there are eight pulses of compressed air per cycle instead of the usual four pulses. This mechanism doesn't compromise the high specific power of the engine, at the

same time it increases the reliability and life, as side thrusts are reduced. Moreover there is uniform loading with this type of arrangement.

WORKING:

For visualizing the working of the double acting type Stirling engine it is essential to bring into picture, the Alpha Stirling engine. Any two neighbouring cylinders form a complete Alpha Stirling engine, in other words the first and the last cylinder form an Alpha engine while the first and second cylinder also form another Alpha engine. There are four possible strokes for an Alpha Stirling engine and at any given time, all these Alpha Stirling engines will be executing one of these strokes, with none of them executing the same stroke. To make possible this beautiful interplay, the phase difference between any two adjacent pistons should be 90° .

With reference to the **Fig 15** , consider the first piston is moving downwards. For ease, let us refer to the Alpha engines formed between the first and second cylinder as the first engine and so on for the remaining cylinders so that the engine formed between the last and the first will be referred to as the fourth engine. Do note that the first engine is formed between the top portion of the first cylinder and the bottom portion of the second cylinder (see picture). As the first piston moves downwards, the second piston also moves downwards transferring the working fluid to the hot side of engine one. As both the pistons are moving downwards, there is negligible change in volume. Hence the first engine is executing process 2-3 on the Stirling cycle (Isochoric transfer of working fluid from the cold end to the hot end). The second piston is moving downwards and is near the BDC now, so as to maintain the phase difference, the third piston should be moving upwards. It becomes clear that second cylinder is executing the power stroke (process 3-4), as the volume of working fluid is maximum and majority of the working fluid is in the hot side. Similarly engines three and four are executing the transfer stroke from hot to cold end and the compression strokes respectively. Do visualize the piston movements of these engines to make the concepts clearer.

For animation visit - <http://www.whispergen.com/main/technology>

BETA STIRLING ENGINE

A Beta Stirling engine is a displacer type Stirling engine with a single displacer and piston arranged within the same cylinder. Usually both the piston and displacer are connected to the same flywheel at different points with a 90° phase difference, unlike the Alpha Stirling engine, where both the pistons are connected at the same point on the flywheel. It is interesting to note that the very first patent by Robert Stirling was in fact a Beta Stirling engine. The original patent is sometimes referred to as an inverted beam engine, because of its similarity in appearance with steam engines which uses a beam linkage between the piston and the flywheel.



Fig(20): An actual Beta Stirling engine.

They are comparatively compact compared to other types of Stirling engines and hence are used for applications where there are space limitations. The power output for a given volume is lower compared to other engines. Incorporation of a regenerator is a bit difficult and since there is no proper insulation between the hot and cold end, the efficiency of the engine goes down as the engine gets warmed up. This is due to conduction of heat from the hot end to the cold end and there will be some drop in the RPM of the engine and hence its power output.

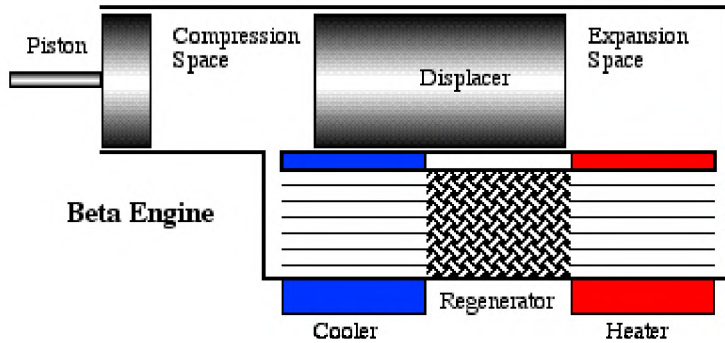

Fig(21): A schematic of a Beta Stirling engine.(linkages are not shown)

WORKING:

The basic working of a Beta Stirling engine is identical to the Alpha Stirling engine which we previously discussed. The differences are mainly in the way the working fluid is moved within the cylinder. The use of a displacer to shuttle the working fluid prevents the use of wire gauze/mesh model of regenerators inside a Beta engine and hence it is usually located outside the cylinder. As we did with the Alpha engine, the visualization of the combined movements of both the pistons is necessary to completely understand the functioning of the engine.

CRANK POSITION WITH RESPECT TO STROKE

For an Alpha engine, differentiating strokes were easy as it coincided with the either one of the pistons at its extreme position. In other words, for every 90° the crank turned from the horizontal position (when the hot piston was at IDC), a stroke was completed.

A little thought will reveal that in case of a Beta Stirling engine the four strokes are not that well differentiated. The power piston in a complete cycle reaches only two extreme positions and that too is not at the start of or at the end of any stroke. The reason for this is because the transfer strokes should be such that there is only a small change in volume. Remember they are isochoric processes.

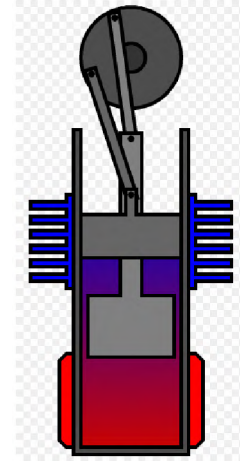
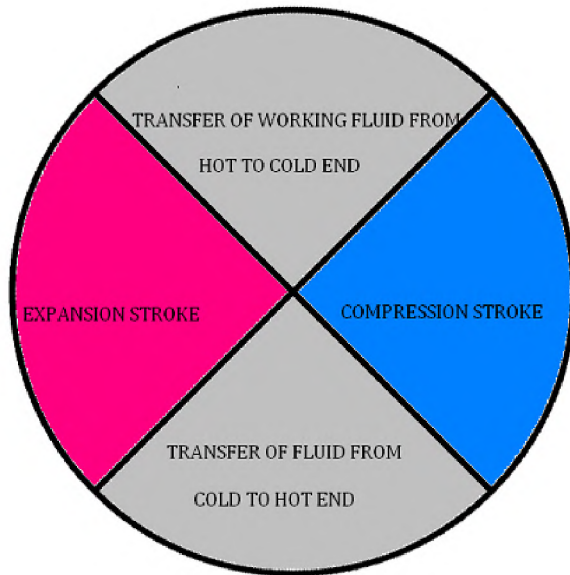

Fig(22): Position of piston on flywheel for different strokes for a vertical Beta engine.

So for a Beta engine maintained vertically as shown in the right figure, the strokes with respect to the crank position of the power piston will be as shown in the figure on the left. For example, for clockwise movement of crank, the 90° turned from the end of the compression stroke will be the transfer stroke for moving the working fluid from cold end to the hot end. Another thing that becomes clear from the figure is the fact that, there is only a small change in the volume of the cylinder during the transfer stroke and considerably large change in volume during the power and compression strokes. For making this clear visualize the engine during the transfer stroke from cold to hot end, the piston moves a little down to reach the BDC and moves a little up to complete the stroke.

The displacer always leads the piston by 90° and so to find its position add 90° to the position of the piston. Note that the displacer doesn't change the volume of the cylinder in any way during its motion. It simply helps in shuttling the working fluid between the hot and cold ends of the cylinder. With this in mind let's see the different working strokes of the engine.

1. Transfer of working fluid from cold side to hot side:

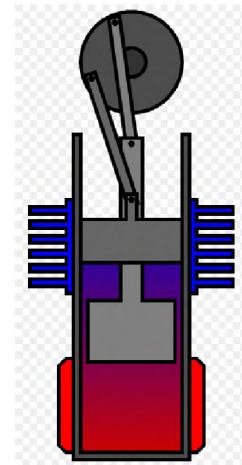
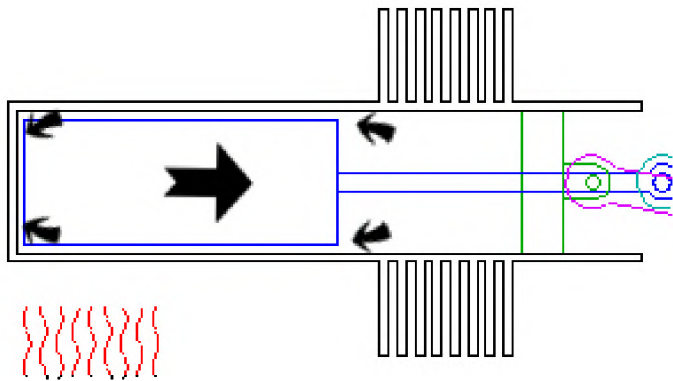

At the moment shown in picture, the displacer (the longer piston, with clearance) is at IDC while the power piston is moving right to IDC. From crank positions on the right figure, the above fact becomes clear. The figure to the left shows the piston and displacer position at the start of the stroke and the figure to the right show their positions at the end of the stroke. (Refer left figure for piston movements and working fluid movements and refer right figure for crank/flywheel positions.).

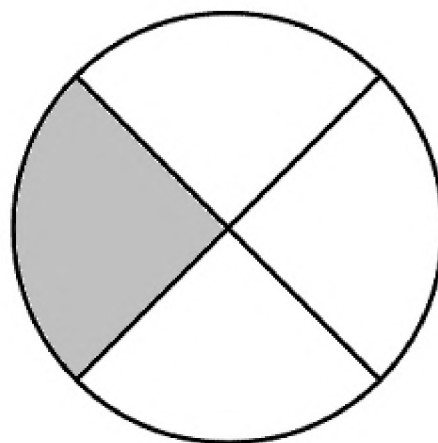
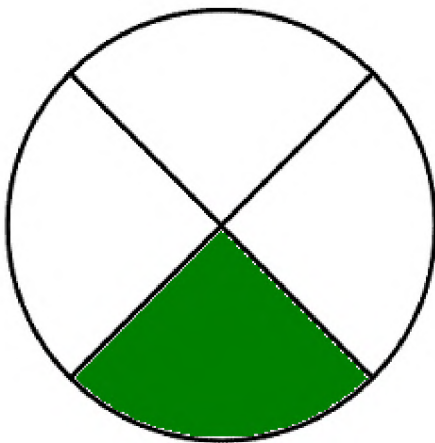

Fig(23-a): Distance moved by piston

Fig(23-b): Distance moved by displacer

As the stroke proceeds, the displacer moves right and the working fluid moves towards the hot side. The power piston and the displacer move out of phase (in

opposite directions) initially and then move in phase. (See the crank position of the piston and displacer from right figure and visualize its position before 90° rotation and understand the piston movements). The piston movement is small for this stroke and there is only a small volume change.

This for all practical purposes will be the constant volume heat addition phase, i.e. the process 2-3 on the Stirling cycle. Since a regenerator cannot be included inside the cylinder, it is usually incorporated outside the cylinder, in between the cold and hot sides of the engine. These are less efficient and hence beta engines are not that efficient. Some Beta engines do not have a distinct regenerator, for these the constant volume heating is usually achieved from the conducted heat from of the hot side of the cylinder, which makes the engine still inefficient.

From the crank angle diagrams predict the motion the motion of the displacer and piston at the end of each stroke. This will make the concepts clearer and will help us when we are visualizing or constructing such an engine.

2. Expansion or power stroke

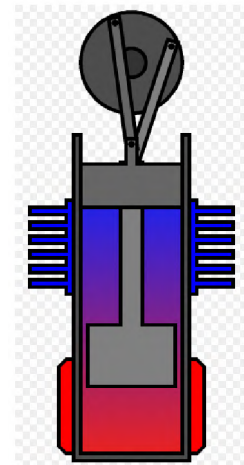
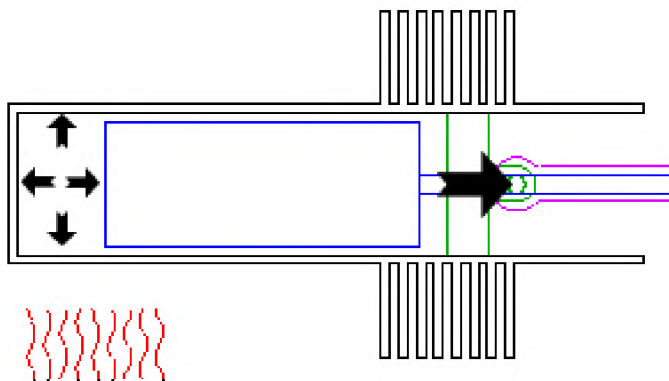

At the end of the transfer stroke most of the working fluid will be in the hot side of the cylinder and displacer and the power piston will be moving towards ODC. The flywheel has turned 90° since the start of the cycle. The working fluid gets heated and expands near isothermally pushing the power piston towards ODC.

The expansion and compression ratios of the working fluid are not as high as in case of the Alpha Stirling engine and hence this becomes another reason as to why Beta engine has a low power output compared to an Alpha engine.

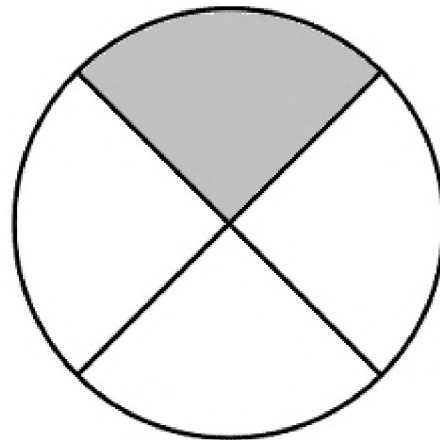
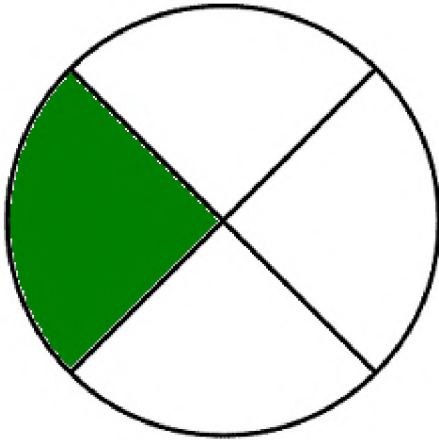

Fig(24-a) Distance moved by piston

Fig(24-b) Distance moved by displacer

From the figures regarding the crank angles turned by the piston and displacer, it becomes clear that, the power piston moves a large distance, while the displacer moves only a short distance. This is the power stroke and it represents the process 3-4 of the Stirling cycle.

3. Transfer of working fluid from hot end to cold end.

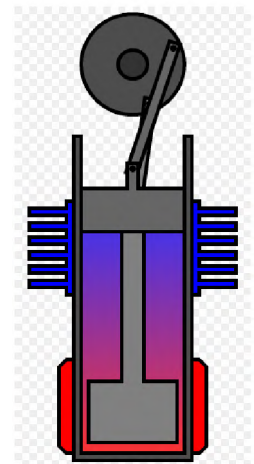
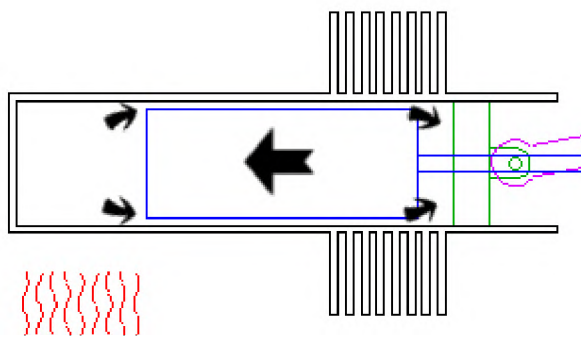

At the end of the expansion stroke, the displacer will be moving towards IDC, while piston moves towards ODC. The flywheel has turned another 90° (or 180° since the start). The working fluid which is hot, now passes in between the clearance of the displacer and moves towards the cold region near the power piston. The movement of the displacer is more in this stroke compared to the movement of the piston.

The working fluid loses heat at near constant volume to the walls of the cylinder which act as a regenerator and this stroke becomes process 4-1 on the Stirling cycle. Now you should be able to make out crank angles turned by the piston and displacer and hence they are not explicitly specified.

4. Compression stroke:

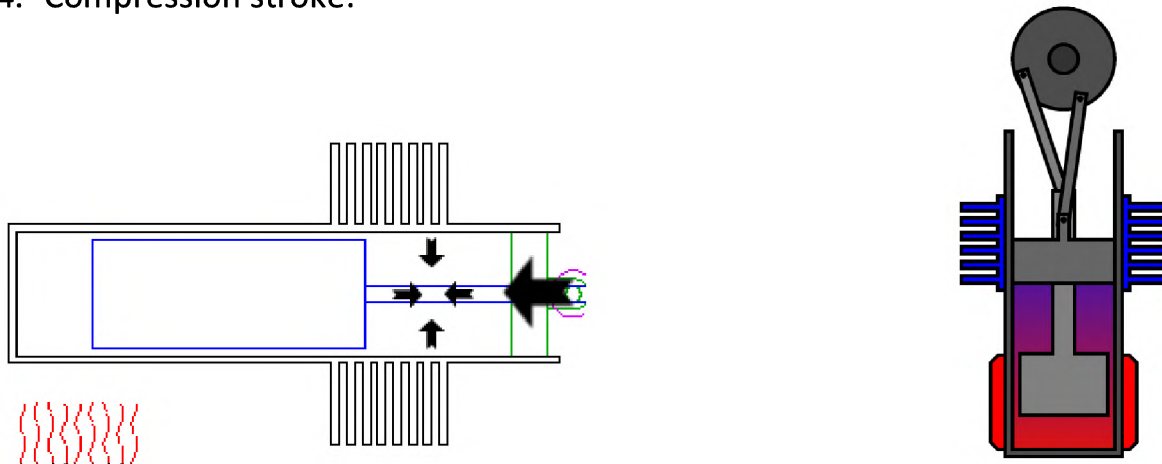

After the flywheel turns another 90° (270° since the start), most of the working fluid is now near the cold section of the cylinder. The piston and the displacer are moving left to IDC. The volume inside the cylinder gets reduced as the stroke proceeds. The working fluid now gets compressed isothermally as it is in contact with the cold reservoir, while it is compressed. This is the isothermal compression (process 1-2) of the Stirling cycle.

At the end of the compression stroke, the transfer stroke starts and the cycle repeats all over again.

For animation visit - <http://www.animatedengines.com/stirling.shtml>

RHOMBIC DRIVE FOR BETA STIRLING ENGINES

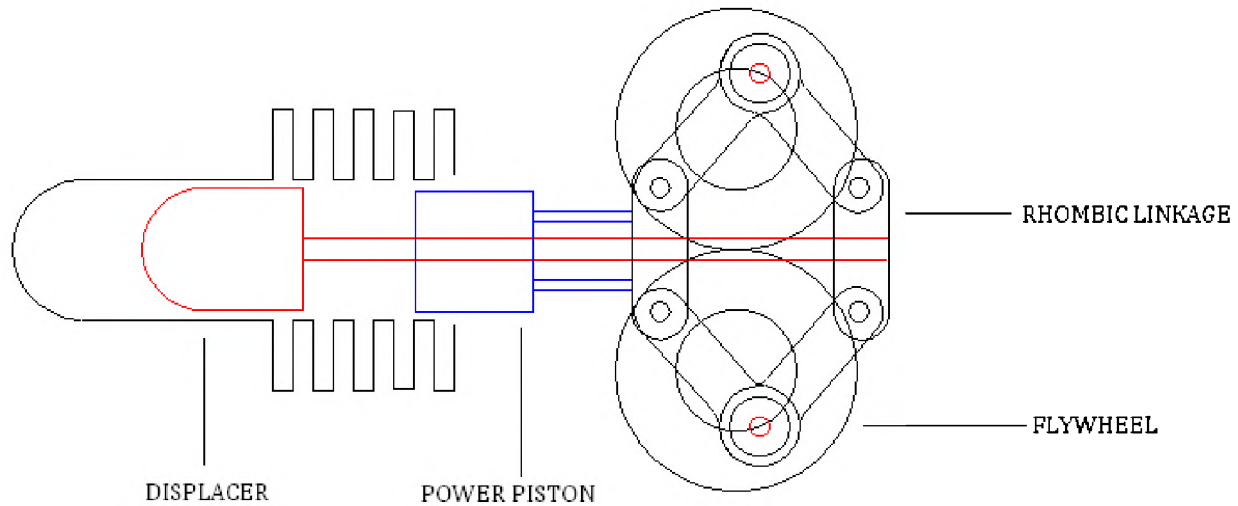

Fig(25): Schematic of a Beta Stirling engine incorporating a Rhombic Drive.

The Rhombic drive is a specific method of transferring mechanical energy, or work developed, when a single cylinder is used for two separately oscillating pistons. The Beta Stirling engine comes under this category. It was Rolf Meijer of Philips company, Holland, who first incorporated this drive into the Beta Stirling engine in 1960's.

As we can see, unlike the conventional drive, the connecting rods are rigid. This makes the drive smooth and vibrationless. Hence they make the engine even quieter and since the motion of the connecting rods is linear, the side thrust is reduced and hence wear on the piston is also reduced. Despite these advantages this linkage is not commonly used due to the difficulty in manufacture and assembly, as close tolerances have to be maintained in both the cases.

For animation visit –

http://www.geocities.com/~rrice2/my_engines/ttr/page3.html

GAMMA STIRLING ENGINE

A Gamma Stirling engine is a displacer type Stirling engine, with the power piston located in a separate cylinder. This allows a complete separation between the heat exchangers associated with the displacer cylinder and the compression and expansion work space associated with the piston. Usually the displacer cylinder is many times larger than the power piston cylinder and hence they tend to have large unswept (dead) volumes compared to Alpha or Beta Stirling engines.

Even though there are two separate cylinders only one of them (the one containing the power piston) has to be sealed unlike the Alpha engine. Moreover the power piston is isolated from the thermal reservoirs and this reduces any variations in the cylinder dimensions due to contraction or expansion. This makes sealing easier unlike other engines, especially the Alpha Stirling engine where the sealing of the hot piston is a real challenge. It is sealing that presents the biggest challenge in most Stirling engine designs as close tolerance running fits have to be maintained for the effective working of the engine. Since the sealing of the Gamma engine is comparatively easier it is a favorite among modelers and hobbyists as they can be easily manufactured in workshops.

Since the heat exchangers are separated from the power cylinder and is integrated on the displacer cylinder which is larger, design and placement of heat exchangers also becomes easier. Larger and better heat exchangers can be integrated as the area available for the purpose is much larger compared to the Beta Stirling engine. As there is considerable flexibility in the design of heat exchangers, even water cooled Gamma Stirling engines, having cooling jackets have been made.

A lot of research has been done on the Gamma Stirling engines due to its relative ease of manufacture. This has resulted in two new types of Gamma Stirling engines called as the Ringbom Stirling engines and the Low Temperature Stirling Engines. The Low Temperature Stirling engines are extremely popular and usually used as demonstration models.



Fig(26) A Gamma Stirling engine

Fig(27) A CAD model showing the cut section of the above Stirling engine

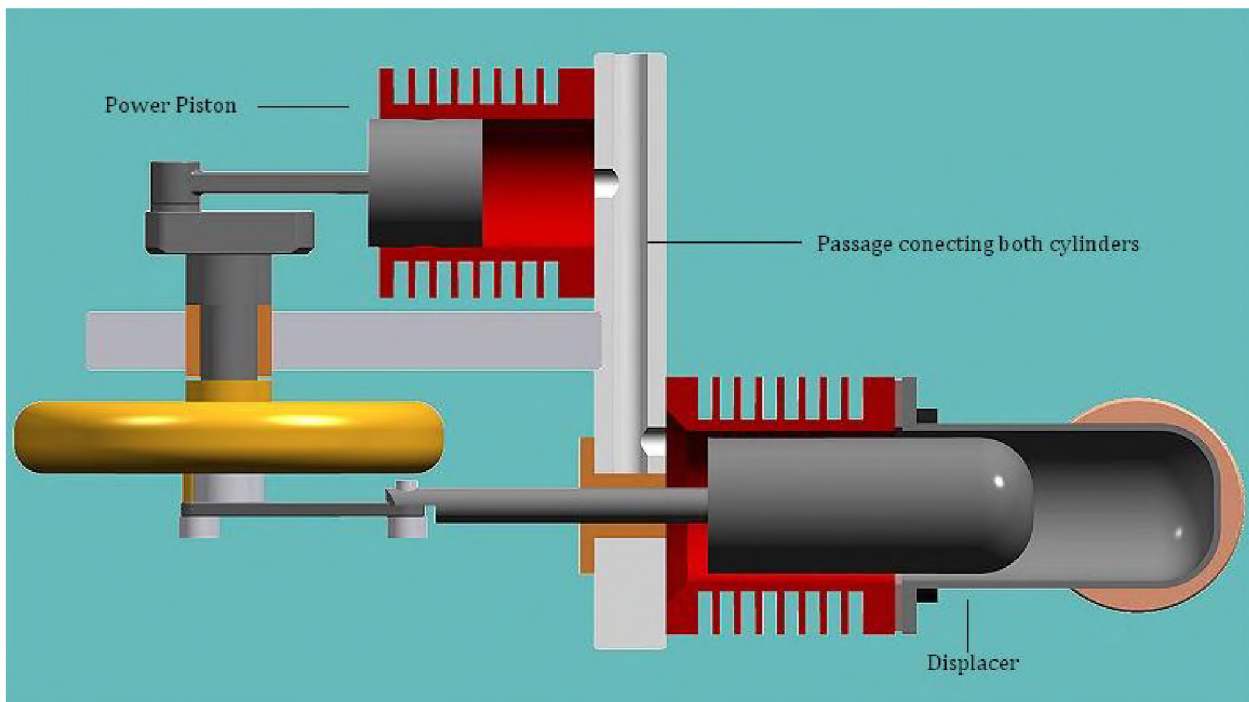

On the downside the Gamma Engines have the least specific power among the three basic types of Stirling engines as during expansion process not all the working fluid reaches the hot region (some remain in the compression space). As a result some of the expansion must take place in the compression space leading to a reduction of specific power. Moreover compression ratios are lower compared to other types. Gamma engines are therefore used when the advantages of having separate cylinders (separation of thermal reservoirs and piston-displacer swept volumes) outweigh the specific power disadvantage.

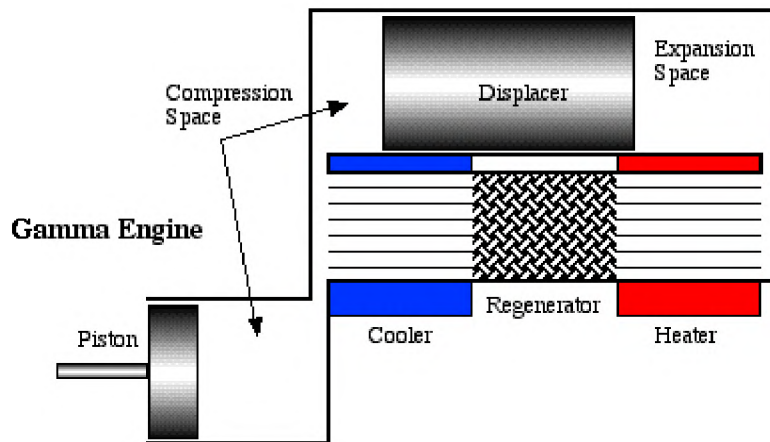

Fig(28): A schematic of a Gamma Stirling engine.(linkages not shown)

Note how the power cylinder is totally devoid of any heat exchangers. Also it is evident that the expanded gases come in contact with the cold reservoir before they come in contact with the piston, resulting in a decrease of power output.

WORKING

The basic working of a Gamma Stirling engine is identical to that of a Beta Stirling engine, both being displacement type engines. The displacer oscillates in a separate cylinder (usually the larger one), while the power piston oscillates in another smaller cylinder. Both the cylinders are linked for the passage of the working fluid between the cylinders. The crank angles turned with respect to the strokes are identical as in case of the Beta Stirling engine and hence are not specified again. Refer to figure (22) for clarifications.

1. Transfer of working fluid from cold side to hot side:

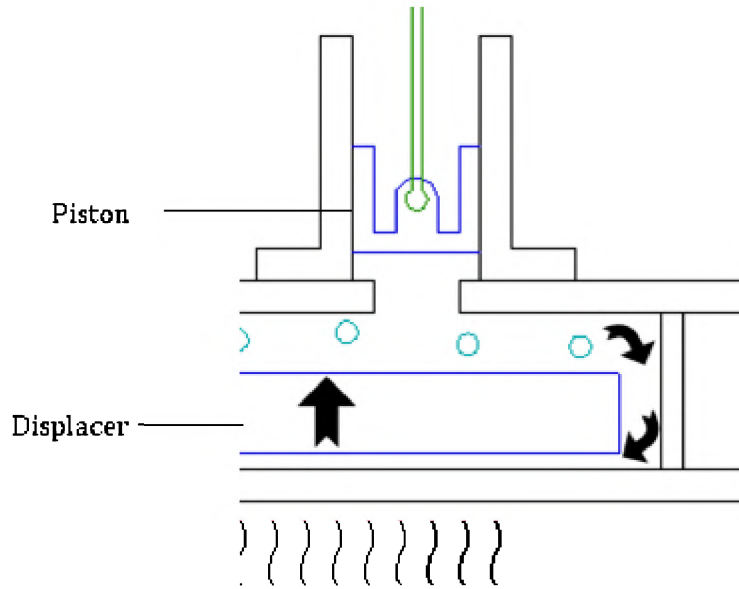

At the start of the stroke most of the working fluid is in the compression space (refer FIG-28). The displacer will be moving up towards the TDC while the piston will be moving downwards. The movement of the piston will be negligible compared to the movement of the displacer and hence for all practical purposes, this is the Constant volume heat addition stroke on the Stirling cycle (Process 2-3).

2. Expansion or power stroke

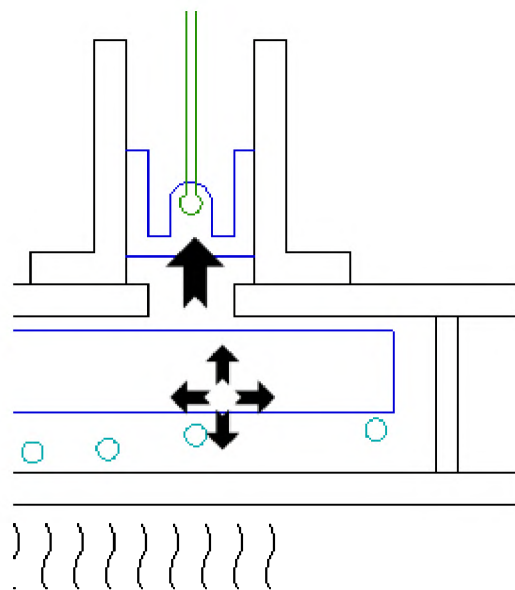

After the flywheel has turned 90° , since the start of the transfer stroke, most of the working fluid is in expansion zone i.e. it is in contact with the hot reservoir. At the start of the expansion stroke, the displacer will be moving up to TDC while the piston will also be moving upwards to its TDC. As the gas expands the gas enters the compression space and pushes the piston upwards. This is the power stroke of the engine and it is shown by the process 3-4 on the Stirling cycle. As previously mentioned not all the expanded working fluid does work on the piston as partial expansion takes place in the compression space. This results in power loss.

Now visualize the piston and displacer movements at the end of the power stroke. It should become clear that the movement of the piston is much more compared to that of the displacer in other words there is a large change in the volume of the engine at the end of the power stroke.

3. Transfer of working fluid from hot end to cold end.

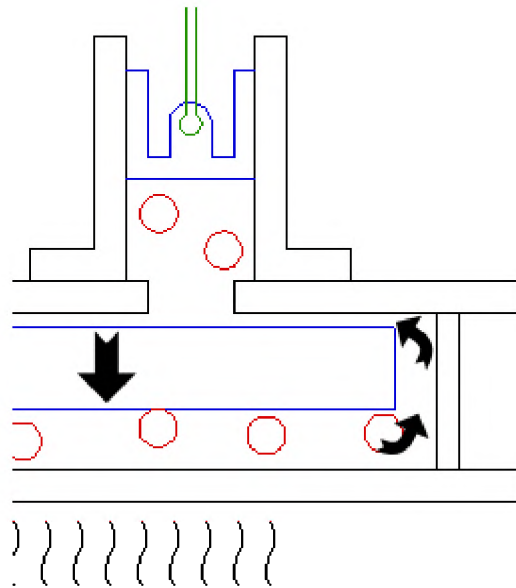

The flywheel has turned another 90° (180° degrees since the start), the working fluid has expanded and most of it is near the hot reservoir. The displacer is now moving towards the BDC while the piston is moving upwards to its TDC. As the displacer moves down it pushes almost all the working fluid to compression

region of the cylinder. The piston moves only a little in this stroke and this stroke is represented by the process 4-1 on the Stirling cycle.

4. Compression stroke

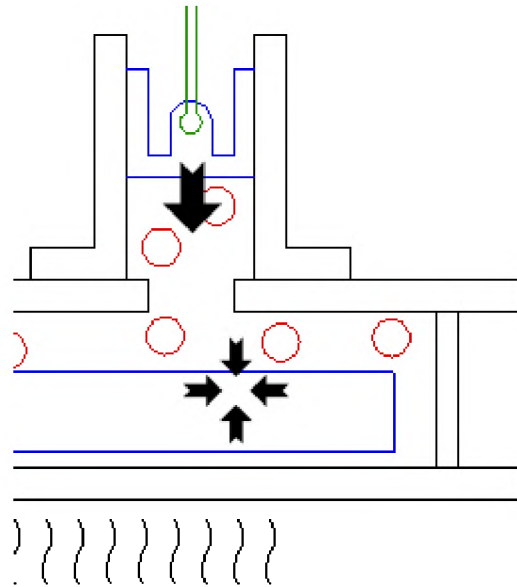

After the flywheel has turned another 90° (270° since the start), most the working fluid is in the compression space. As the piston moves down towards BDC, the effective volume inside the cylinders is reduced. The working fluid which is now in contact with the cold reservoir is compressed. Not all the working fluid is in contact with the cold reservoir as the compression space extends into the power piston cylinder which not in contact with any thermal reservoir. This increases the work required in compression and the effect is reduced specific power output. If the cold reservoir is the atmosphere, this effect is somewhat negligible.

This stroke is represented on the Stirling cycle as process 1-2. The compression ratios for a Gamma Stirling engine is much smaller compared to other types as the swept volume of the power cylinder is much smaller compared to the total volume of the engine.

For animation visit - <http://www.animatedengines.com/ltdstirling.shtml>

LOW TEMPERATURE DIFFERENTIAL STIRLING ENGINE

As we have seen earlier all Stirling engines require a temperature difference to be maintained between hot and cold ends of the engine, usually of the order of a few hundred degrees Celsius. In the 1980s, Professors Ivo Kolin and James Senft developed a series of engines exploring the minimum temperature differential that could be made to work. Dr. Senft's basic design has been widely copied and is now available as a kit or completed engine from a number of model engine manufacturers. The heat from a cup of coffee is usually enough to power it and hence are sometimes referred to as Coffee Table Stirling Engines. If carefully constructed, it will even run from the warmth of your hand i.e. a temperature difference of only 2°C to 6°C.

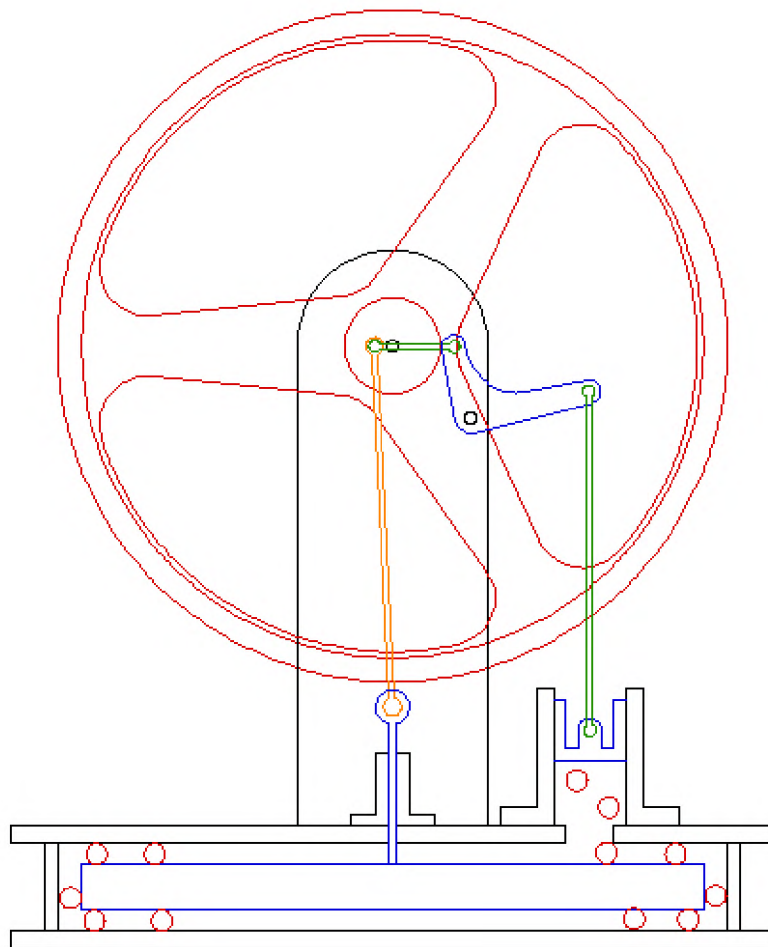

Fig(29): A cut section of a low temperature differential Stirling engine.

The most usual configuration is a Gamma type Stirling engine with large diameter displacer, with no regenerator. In some cases the displacer is made of foam and provides partial regeneration. The displacer cylinder is made quite short for its diameter, and encloses a matching short-stroke displacer cylinder. Typically the power piston and cylinder is mounted on the top plate of the displacer cylinder. They are typically unpressurized and have air as the working fluid. The power produced by these engines is extremely less, usually of the order of 1W and hence are most commonly used as toys and demonstration models.



Fig(30): Dr Senft's "Heat of your Hand" engine design. A Model MM-7 Stirling engine made by the American Stirling company.

The model MM-7 engine, shown in the above figure, works on a temperature difference of about 4°C . The current record for the lowest temperature difference on which a Stirling engine worked is 0.5°C , which was set in 1990.

RINGBOM STIRLING ENGINES

Ringbom Stirling engines are Gamma type Stirling engines in which the piston is coupled to the flywheel but the displacer is not. The displacer is usually guided but there are no mechanical linkages from it. The displacer always leaves a large clearance with the BDC; this limiting position is achieved by stops. This engine is sometimes called as the Thumper due its distinctive sound made by the displacer as it collides against the stops, during either directions of travel.

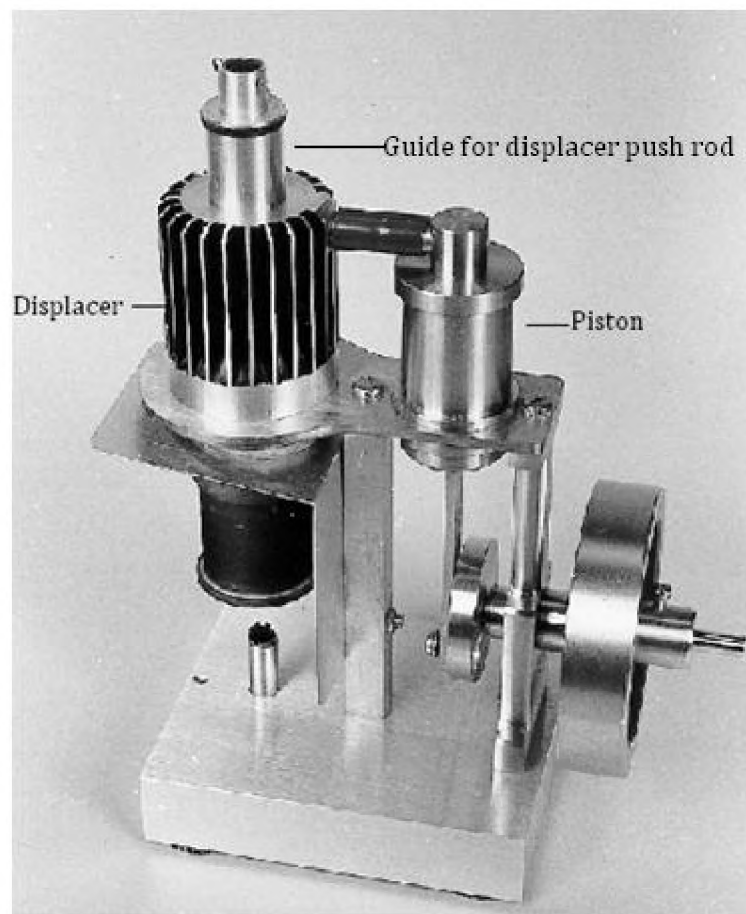

Fig(31): An actual Ringbom Stirling engine.

The displacers in a Ringbom Stirling engines have larger push rods (the rigid connecting rod of the displacer piston which is guided). The push rods have close

running fit like pistons. It is the gas pressure forces acting on an equivalent area of the push rod that causes the displacer to move up and down.

Working:

Let us see the working of a simple Ringbom Stirling engine, in which the mean operating pressure is roughly the same as the atmospheric pressure. Since Ringbom engine is essentially a Gamma Stirling engine, we will not delve deep into its working but we shall try to understand how the displacer moves at the required phase difference (with the power piston) in the absence of a mechanical linkage.

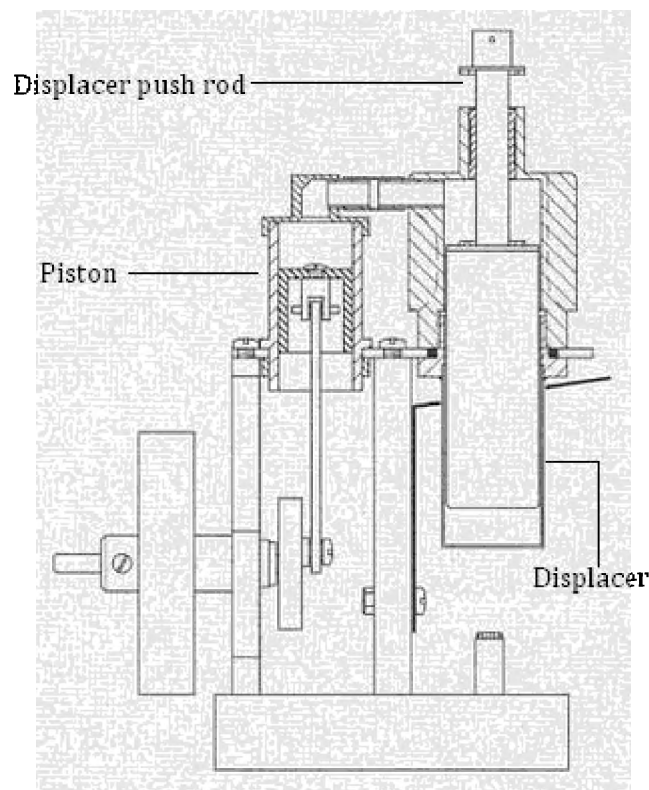

Fig(32): A cut section drawing of a Ringbom engine.

The state shown in the figure is near to the end of the compression stroke, when the pressure inside the cylinder has risen and the bulk of the working fluid is in the compression space. As the pressure inside the displacer cylinder increases the force acting on the displacer also increases. Since the displacer cylinder is

uniformly pressurized, the pressure on the top and bottom will be nearly equal. But the forces acting on the top and bottom surfaces are not equal due to difference in areas as a result of the presence of the push rod on the top surface. The result is an equivalent upward force equal to pressure times pushrod area acting upwards. (Push rod area is the difference of areas of top and bottom surfaces on which the gas pressure acts.) When this force exceeds the weight of the displacer acting downwards (which includes the atmospheric force acting on the displacer pushrod from outside in the downward direction), the displacer piston moves upwards. As the compression stroke proceeds, the pressure rises even more and hence the force acting on the displacer also increases causing it to move upwards with increasing acceleration.

*In order to completely understand the cycle, refer to the Gamma engine piston and displacer movements corresponding to each stroke and carefully visualize the pressure variations inside the engine. Also make use of the Stirling cycle to complete the picture. The piston and displacer movements specified below are with respect to the Ringbom engine shown in **FIG(32)***

1. Transfer of fluid from cold to hot end:

At the movement, the displacer is moving with increasing acceleration (see the Stirling cycle, the pressure increases during the constant volume process 2-3 due to constant volume heat addition from the regenerator) upwards, displacing the working fluid towards the hot side of the engine. Refer to the Stirling cycle and give importance to the pressure variations in each stroke. Also remember $P_{\max} > P_{\text{atm}} > P_{\min}$.

2. Expansion or power stroke

At the start of this stroke, the pressure will be maximum. The piston starts moving downwards, and the gas starts expanding. The pressure falls and the displacer starts to decelerate and soon comes to a halt as it strikes the top stops, and a characteristic thumping sound is heard. Near to the end of the stroke the pressure falls nearly below the atmospheric pressure and the displacer is pushed downwards by the atmospheric pressure.

Note this process 3-4 on the Stirling cycle is accompanied by a gradual drop in pressure.

3. Transfer of working fluid from hot to cold end.

The pressure inside the displacer cylinder further drops as the transfer stroke starts. See process 4-1 on the Stirling cycle. The displacer moves with increasing acceleration downwards and the working fluid is shuttled to the cold end of the cylinder. At the end of this process, theoretically the pressure will be least and the displacer will be downwards, while the piston starts to move upwards.

4. Compression stroke.

As the piston starts to move upwards for the compression stroke, the pressure inside the engine starts to increase. This causes the displacer to decelerate and it soon comes to a sudden halt against the rests with a thumping sound. As the pressure inside the cylinder starts to increase, at a certain point when the gas forces exceed the weight of the displacer, it starts moving upwards. This is process 1-2 on the Stirling cycle and at the end of it, we reach the transfer process and the cycle repeats all over again.

FREE PISTON STIRLING ENGINES

Free Piston Stirling engine is the general term given to those which have pistons which are not mechanically connected to a flywheel. There are types that even have liquid pistons or diaphragms to do the job of mechanical pistons. Since there is no connecting rod and flywheel arrangement to convert the linear motion of the piston into rotary motion, some co-axial devices have to be used to harness the produced work. The most commonly used co-axial device is the linear alternator. Another application of the free piston Stirling engines is to function as a pump, as linear motion of piston can be easily integrated for that purpose.

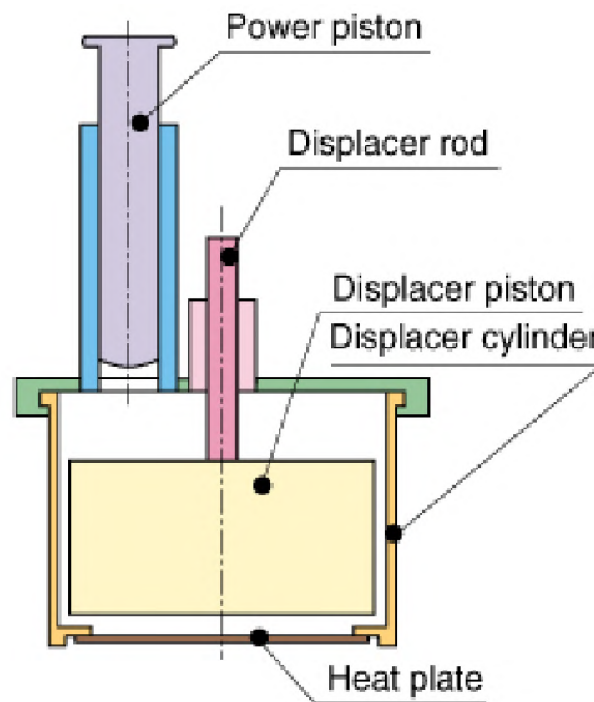

Fig(33): A free piston Stirling engine, featuring gravity aided power piston.

W.T Beale is credited with the invention of the free piston type of Stirling engines to overcome lubrication problem of the crank mechanism, in 1960. Since then a large variety of free piston Stirling engines have been developed. Many use springs, gravity or inertial masses to supply the work needed for the compression stroke.

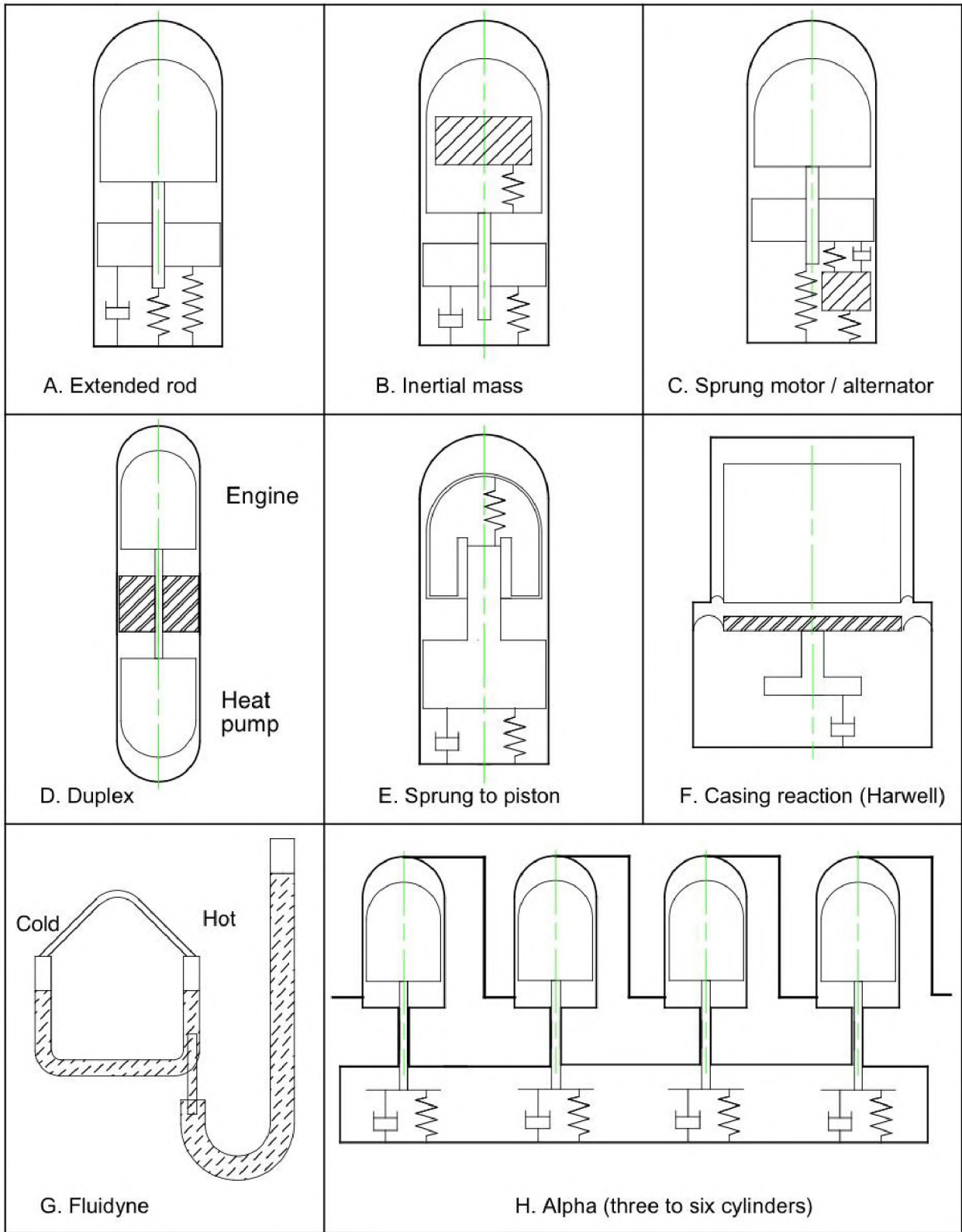

Fig(34): Some types of free piston Stirling engines. Note the use of inertial masses and springs. Source: WIKIPEDIA

WORKING:

The working of most free piston Stirling engines is identical to that of the Ringbom Stirling engine. Let us see briefly the working of a free piston Stirling engine, where gravity powers the piston of the Stirling engine for the compression stroke. In other versions where gravity is not the predominant, either springs or inertial masses are provided, which provide the necessary energy for the compression stroke. Displacer movements are identical to that of the Ringbom engine; hence refer to the working of the Ringbom engine if need be.

1. Transfer of fluid from cold to hot end:

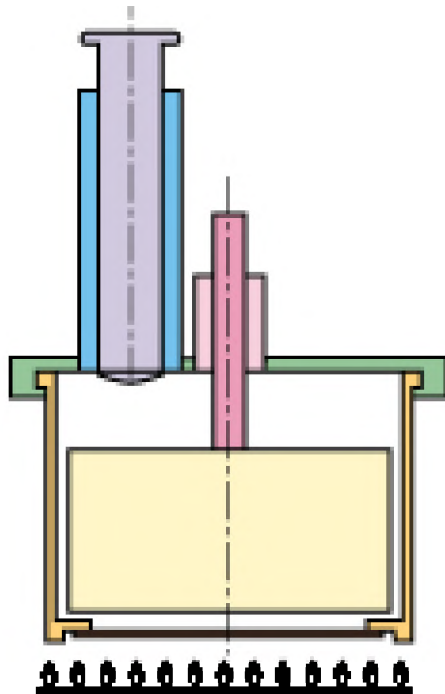

At the start of the transfer stroke, the pressure inside the engine will be higher and similar to what happened in the Ringbom engine, the displacer is pushed upwards. The bulk of the working fluid is moved to the hot end of the engine. Visualize the positions of the displacer and the power piston at the end of the stroke.

2. Expansion or power stroke:

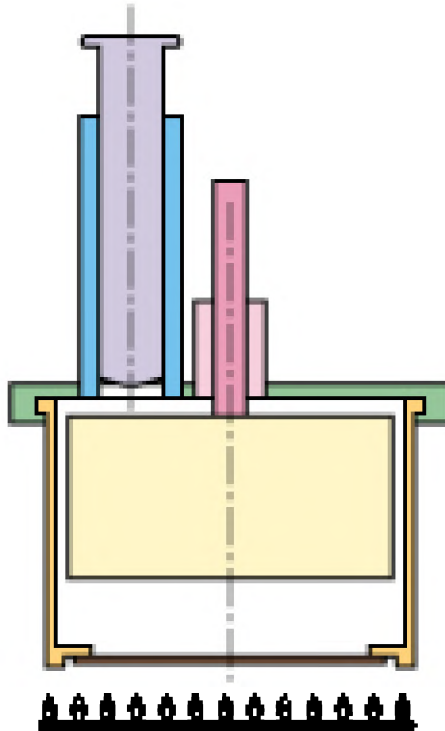

At the start of the expansion stroke, the pressure is highest (refer Stirling cycle) and this pushes the power piston outwards, increasing the volume inside the engine. The gas further expands pushing the piston upwards, while its pressure falls. At the end of the stroke the power piston will be moving towards TDC.

3. Transfer of fluid from hot to cold end:

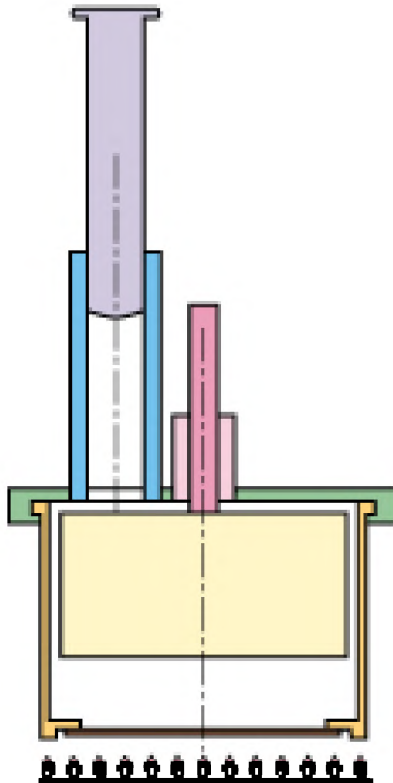

Once the pressure inside the engine falls near to the atmospheric pressure, the displacer starts moving downwards. This forces the displacer downwards and hence the working fluid is shuttled to the cold region of the engine. This continues till the displacer nearly reaches the stops at BDC and the piston starts moving downwards.

4. Compression stroke:

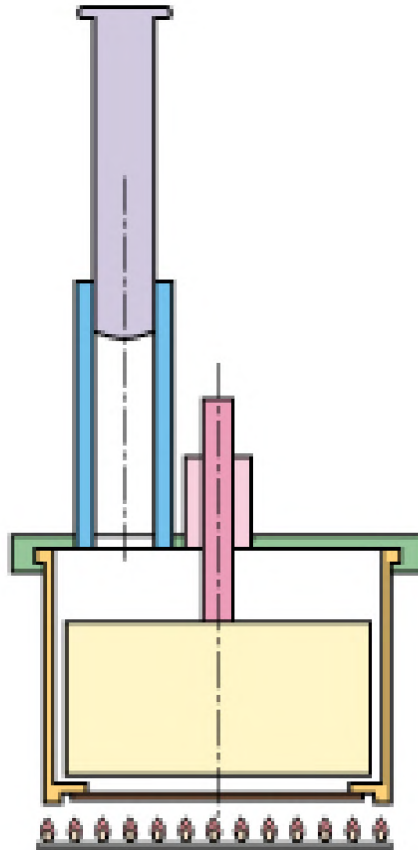

The weight of the piston powers the compression stroke. The atmospheric pressure also aids in the compression stroke initially, but its effect becomes negligible as the stroke proceeds. As the piston falls under gravity, the volume inside the engine reduces and working fluid is compressed. The piston at the end of the stroke gradually decelerates due to the increasing pressure inside the engine and nearly reaches the BDC at the end of the stroke. Due to increased pressure the displacer starts moving upwards and the cycle repeats all over again.

FLUIDYNE ENGINE

These are Alpha or Gamma type Stirling engines with one or two liquid pistons. They are commonly referred to as Liquid Piston Stirling Engines. The displacer may or may not be liquid in the case of Gamma configuration. The use of liquid pistons makes most of the Fluidyne engines self starting as starting friction is reduced to a great extent. Moreover problem of sealing of pistons is totally eliminated with well designed liquid columns. Vaporization of the liquid in the hot regions of the engine severely reduces the efficiency of the engine. By preventing this efficiency can be improved tenfold. Increasing the mean working pressure or incorporating a float at the hot end can reduce this problem.

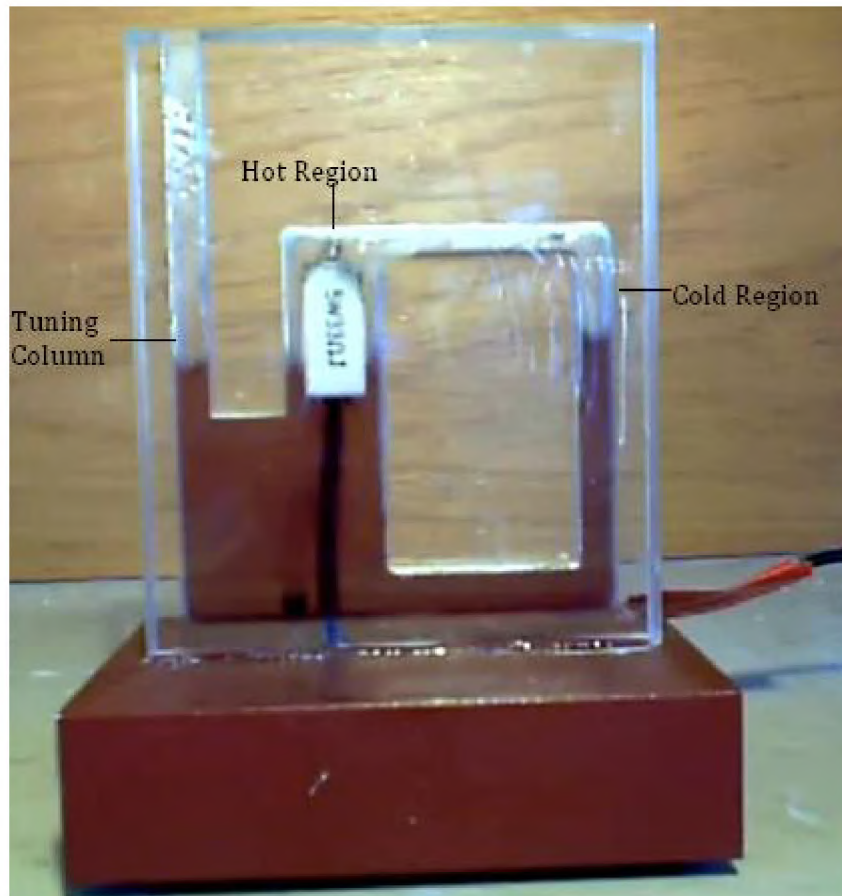

Fig(35): An actual Fluidyne engine.

The tuning column is equivalent to the power piston of a conventional Stirling engine, as the movement of that column of liquid alters the engine volume. A little thought will reveal that the above configuration (FIG-35) is a Gamma Stirling engine, as the tuning column (the power piston) is located in a separate column, while the heat exchangers are in a separate section. More over the section in contact with the heat exchangers becomes displacer, as its movement never alters the volume of working fluid inside it. The heating for this particular case is done using resistance heating.

The design of a successful Fluidyne engine revolves around the oscillating frequencies of the liquid column. Maximum power output is obtained when the frequency of operation of the engine should be equal to the natural frequency of the column i.e. at the resonant condition. The natural frequency of the liquid columns can be varied by changing length of the length of liquid in the tuning column and hence the name tuning column.

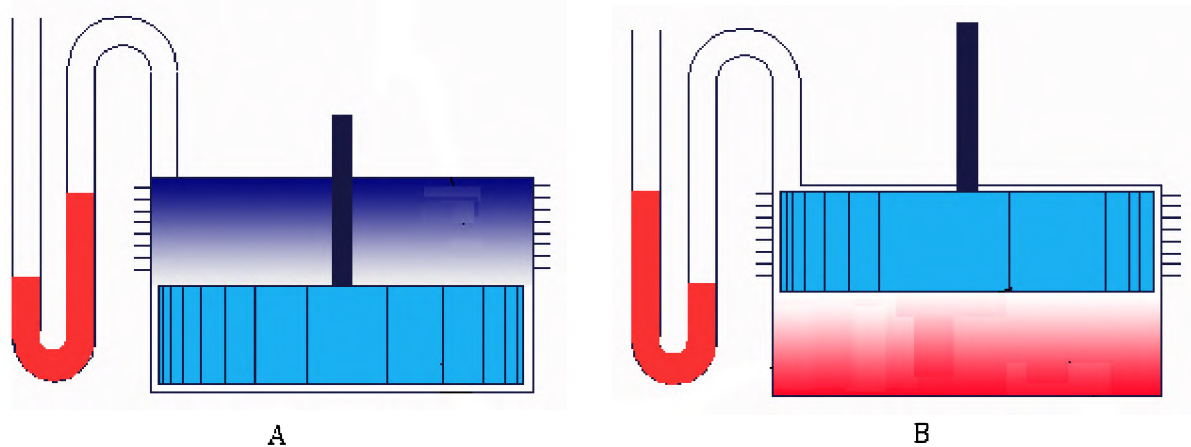

Fig(36): A fluidyne engine with solid displacer and liquid piston. Figures A and B indicate two different strokes.

Fluidyne engines with liquid pistons and solid displacer have also been made. One significant use of Fluidyne engine is to utilize the up and down motion of the liquid piston for the pumping of water.

FLUIDYNE PUMP

When a Fluidyne engine is used for pumping fluids, it is called as a Fluidyne pump. Using a pair of non return valves we can implement a Fluidyne pump using the Fluidyne pump. When the liquid column in the tuning column goes down, the pressure drops and the valve near the sump opens to let water in. Now during the power stroke, liquid column goes up pushing the fluid out of the delivery valve. Even though it simple, there are problems with the operating frequency of the engine when the length of the liquid column changes. A number of researches are being carried out to make an efficient Fluidyne pump.

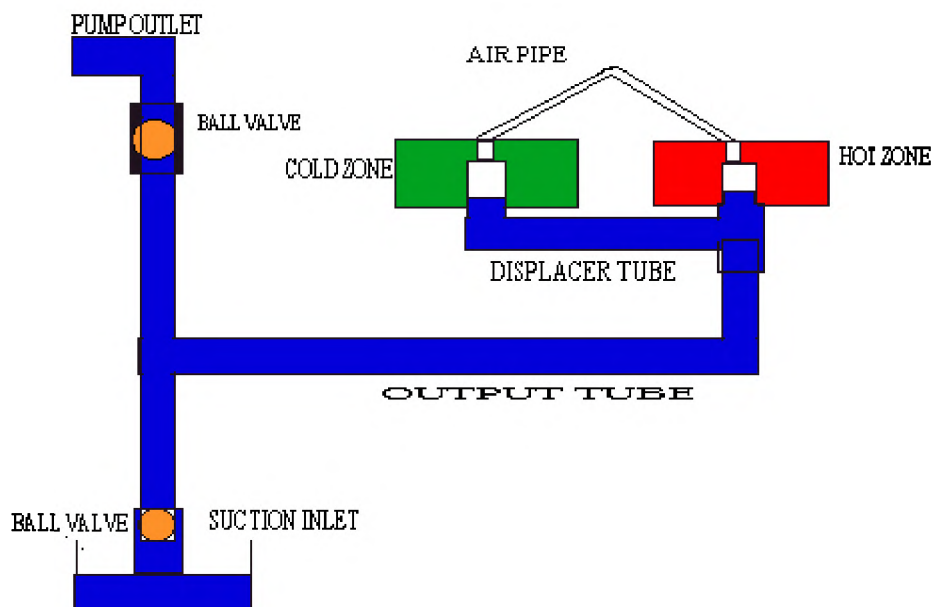

Fig(37): A schematic of a Fluidyne pump

In addition to the above stationary model Fluidyne pump a number of other types of pumps have been designed using the Fluidyne engine. The famous see saw pump is a classic example of the Fluidyne pump. These are widely discussed nowadays as they have tremendous application in irrigation, especially underdeveloped regions where there is no electricity. Solar energy can be utilized to pump water in these regions.

FREE PISTON ALTERNATOR STIRLING ENGINE

The work developed by a free piston Stirling engine maybe directly converted to electrical energy by coupling the reciprocating piston to a linear alternator. Such a Stirling engine is sometime referred to as a free piston alternator Stirling engine. Since the output of these engines is directly converted to electrical energy, the entire setup including the alternator can be hermetically sealed. Problems associated with working fluid leakage can thus be eliminated.

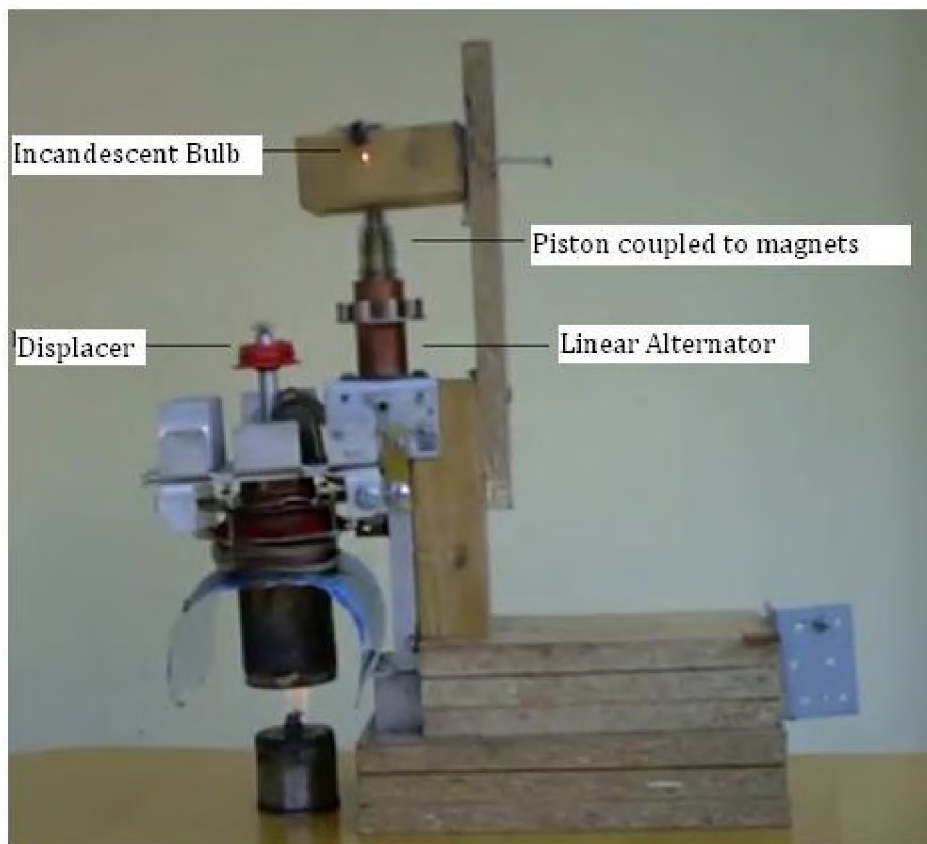

Fig(38): An actual free piston Stirling engine, incorporated into a Linear alternator.

The free-piston alternator engine is ideally suited to the task of developing electricity from solar energy, especially when matched to a low-cost plastic film concentrator of the type now coming on the market. Such machines are being actively developed in sizes up to 10 kW, and could be available in even larger sizes in a few years. These with proper research can be used as an efficient alternative to the solar cells where feasible.

MULTIPHASE STIRLING ENGINE

The Multiphase Stirling engine is an interesting new type of Stirling engine that has three double acting free piston Stirling engines arranged in a triangular form. The engine was developed as a research project at UC Berkeley by Artin Der Minassians and Professor Seth R. Sanders.

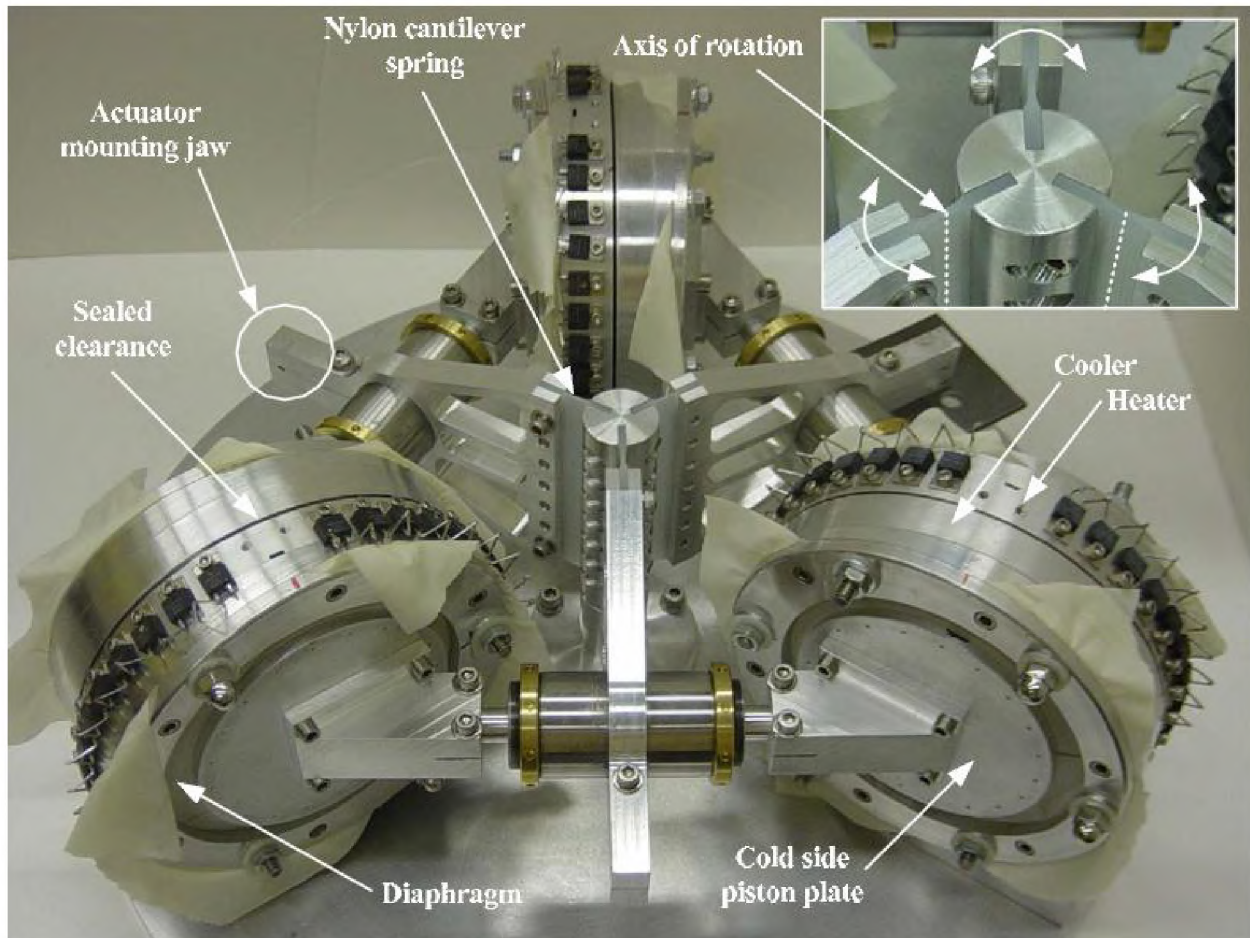

Fig(39): The Multiphase Stirling engine fabricated at Berkeley

The engine developed at Berkeley is reportedly a low temperature differential Stirling engine, which could produce an output of nearly 12.7 watts. It is said that the power produced by photovoltaic cells cost around \$5 per watt, while technologies like this could bring down the power cost to around \$1 per watt.

DESCRIPTION:

The developed multiphase Stirling engine consists of three alpha free piston Stirling engines arranged at a phase difference of 120° with respect to each other. The pistons are double acting i.e. they act as the expansion piston of one cylinder and compression piston of another cylinder. The piston linkages are supported by nylon springs which are connected to a central column to damp the vibrations. The piston linkages are coupled to magnets which are parts of linear alternators. The hot and cold regions of the engine cylinders are insulated by placing an O-ring and regenerators are also incorporated there. Even though we can see piston linkages outside, the job of the piston is done by rubber diaphragms, which are coupled to the piston linkages.

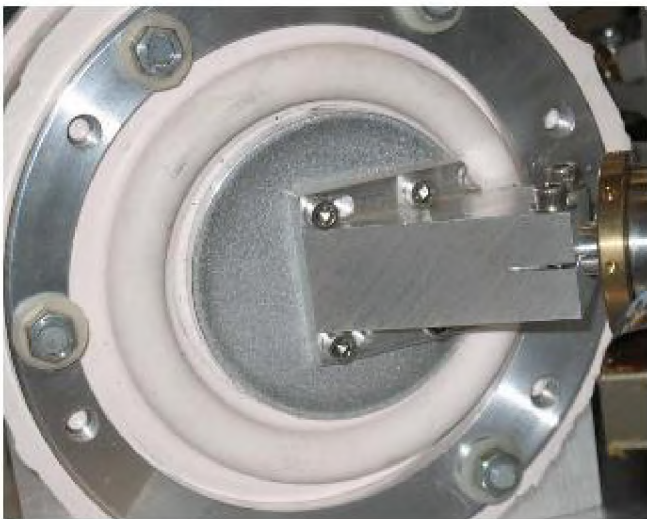

Fig(40-a): Diaphragm pistons



Fig(40-b): Diaphragms after moulding

The use of diaphragms reduces the friction between the cylinder piston interfaces. This makes the engine self starting. The power output is directly in form of electrical energy, which is taken out through the leads from the linear alternator. Ambient pressure air was used as a working fluid in the prototype engine. A lot of research is being done on this engine and engines with more phases (6 phase) engines are predicted to be more efficient than this one.

ROTARY STIRLING ENGINE

This is a Stirling engine in which the power developed from the Stirling cycle is directly converted to torque. The engine will more or less be like the Wankel engine, a rotary internal combustion engine.

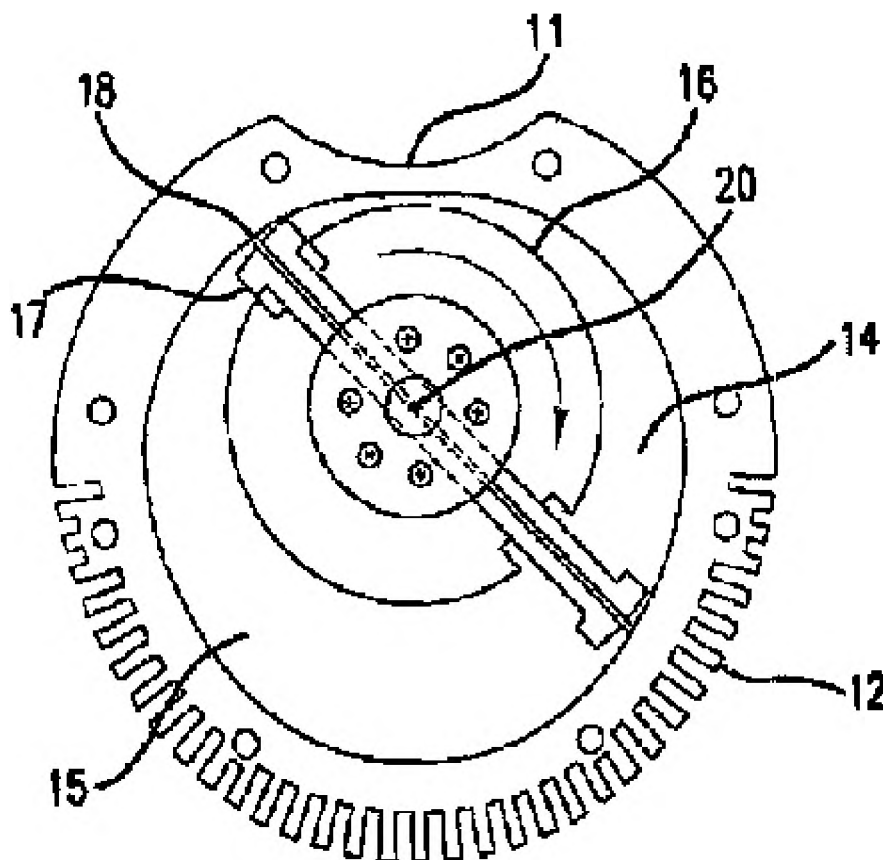

Fig(41): Drawing of a patent made by Robert L Dieter for a rotary Stirling engine with sliding pistons (2005)

A lot of researchers are currently working hard to develop a practical rotary Stirling engine. As of now there are no practical models, even though a number of prototypes and a number of patents have been made. A number of concepts like the sliding piston Stirling engine and a variant of the Quasiturbine engine (concept rotary internal combustion engine) have received a lot attention.

STIRLING CRYOCOOLERS

We all know that when the Carnot cycle is reversed it becomes a basic refrigeration cycle. Similarly the Stirling cycle can be reversed and this is the principle behind the Stirling cryocoolers. Even though the Stirling engine was patented in 1916, the concept was not used as a refrigeration cycle until 1834, when John Hershel used a closed cycle Stirling engine to make ice. The first Stirling-cycle cryocooler was developed at Philips in the 1950s and commercialized in such places as liquid nitrogen production plants.

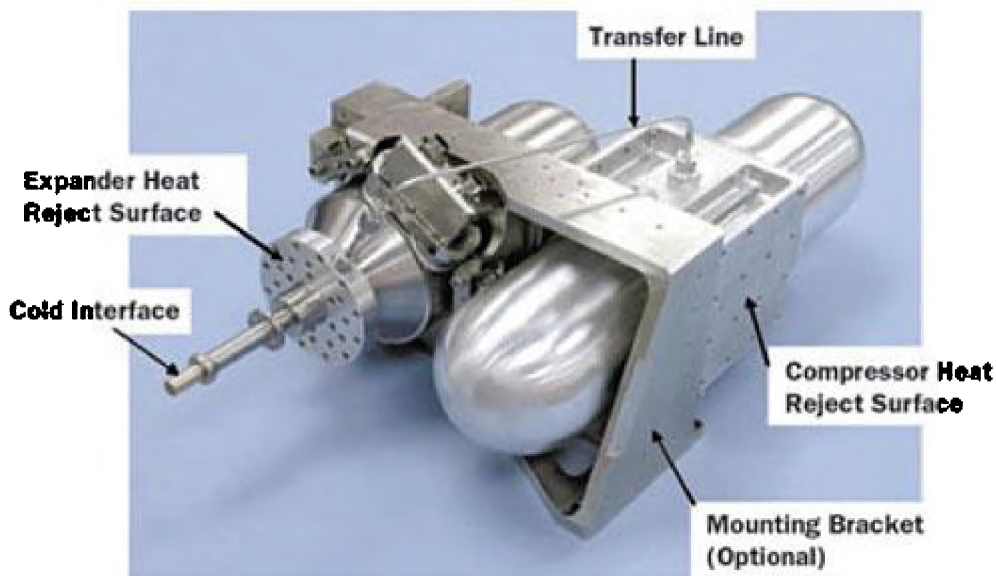

Fig(42): Raytheon Stirling one-stage cryocooler. Produces 4W refrigeration at 60K for 120 W input power.

The Stirling cryocoolers have found excessive application in Defense and Space related fields. They are widely used in thermal imaging satellites, for producing low temperatures, to improve the signal to noise ratio. They are preferred in these applications due to their capability to produce very low temperatures with minimum vibration and due to their high life. Recently they have received a lot of attention due to the fact that they produce low temperature with working fluids such helium and hydrogen in contrast to Vapour Compression Refrigeration Systems which make use of refrigerants which are harmful to the atmosphere.

REVERSED STIRLING CYCLE

By reversing the order in which the processes are carried out in a standard Stirling cycle we get the reversed Stirling cycle. For achieving this cycle work is given as the input and heat is absorbed during one process while it is rejected during another.

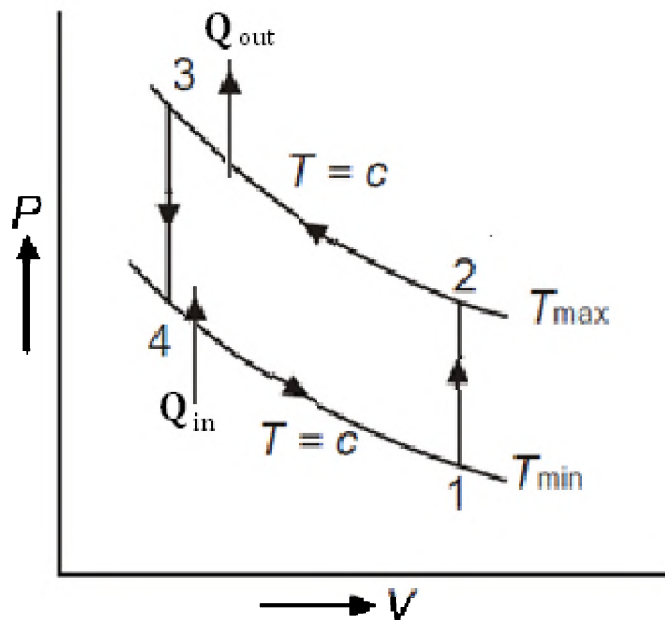

Fig(43) The reversed Stirling cycle.

Process 1-2: Isochoric heat addition:

The working fluid comes in contact with the regenerator and absorbs heat from it. Temperature, entropy and pressure of the working fluid increases. This can be compared to compression process of the standard Vapour compression refrigeration cycle.

Process 2-3: Isothermal compression:

The working fluid is compressed isothermally. As any fluid is compressed, its temperature rises, for making the process isothermal work done on the fluid is rejected as heat. The pressure of the working fluid rises while its entropy falls. This can be compared to the condensation process of the standard Vapour compression cycle.

Process 3-4: Isochoric heat rejection:

The working fluid comes in contact with the regenerator and since the regenerator is at a lower temperature, it is heated by the working fluid. Temperature, pressure and entropy of the working fluid falls. This can be compared to the expansion process in a Vapour compression cycle.

Process 4-1: Isothermal expansion:

The working fluid expands, and as it does so, its temperature drops. To keep the temperature constant, the working fluid takes in heat from the surroundings. The pressure of the working fluid falls while its entropy increases. This can be compared to the evaporation process in a standard Vapour compression cycle.

WORKING:

We know from the gas laws, when a gas is compressed its temperature rises and when it is expanded the temperature falls. This principle is utilized in a Stirling cryocooler. Mechanical work is given to the shaft/flywheel for compressing the working fluid. In practice, a Stirling engine can be converted to a Cryocooler with no major changes just by supplying shaft work to it.

The object to be cooled is kept in contact with the expansion space (it would be identical to the hot region of the Stirling engine). As the gas made to expand, its temperature falls and this initiates a heat transfer from the surroundings into the expansion space. During the subsequent stroke, it comes in contact with regenerator and gets heated. At the start of the compression stroke almost all the working fluid will be in the compression space (the cold region of a Stirling engine). The temperature rise during compression initiates a heat to the surroundings and cycle continues. Thus whole effect of the cycle is to take in work and heat from a low temperature region and reject it at a high temperature region.

DUPLEX STIRLING ENGINE

The Duplex Stirling engine is an interesting version of the Stirling engine which is infact a heat driven cooling machine i.e. it takes in heat and produces a low temperature without any other effect.

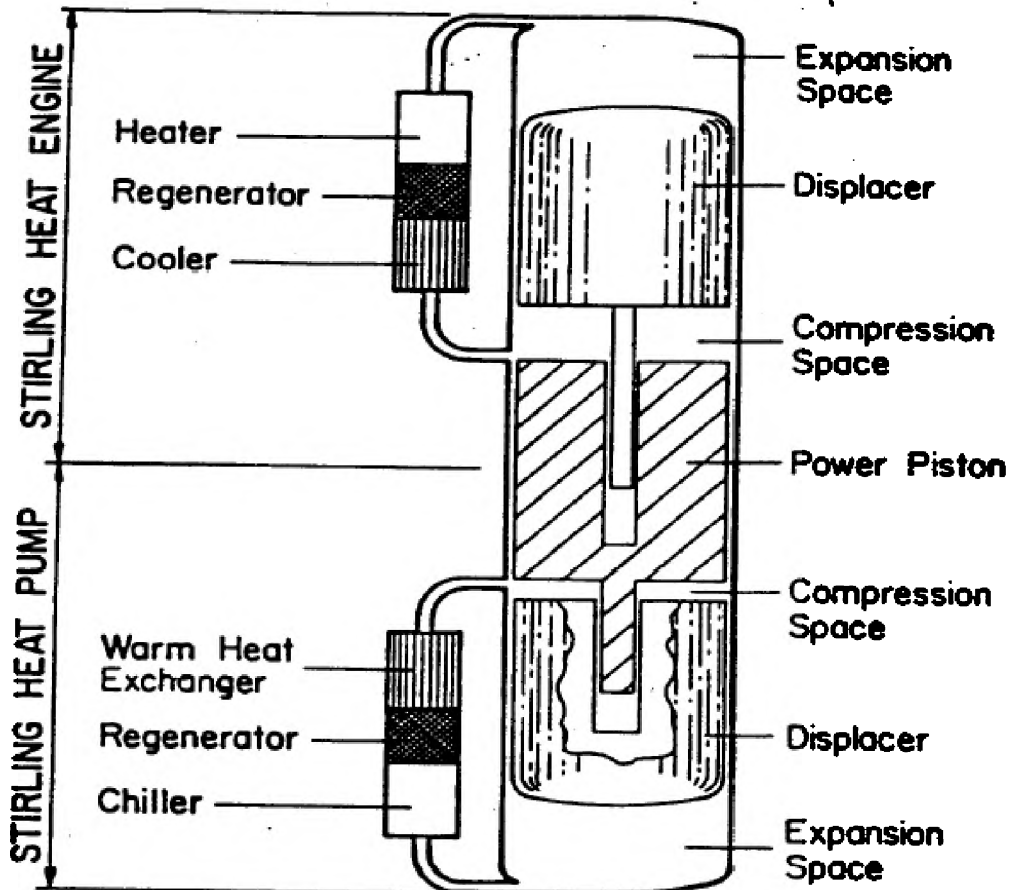

Fig(44) A schematic of the Duplex Stirling engine.

Basically Duplex Stirling engine consists of a free piston Stirling engine (the top half) coupled to a Stirling cryocooler (bottom half). The Stirling engine takes in heat from the heat source and develops work which powers the cryocooler. If designed well they can have very high efficiencies. This is a promising engine that be used as a portable refrigerator with proper design.

PERFORMANCE OF STIRLING ENGINES

STRENGTHS:

1. Stirling engines can run from any available heat source and this makes engine a viable option to harness the solar energy.
2. The engine works on a closed cycle and hence the working fluid is unpolluted and homogeneous. This increases the life of the engine as there is very little corrosion or associated problems.
3. In contrast with the internal combustion engines which have intermittent combustions (which is less efficient), the Stirling engine can have a continuous combustion external heat source. Remember most of the smoke comes when a fire starts, hence with continuous combustion the emissions can be reduced by a large amount.
4. As the working fluid is sealed inside the engine, no valves or associated mechanisms are needed for the engine making it much simpler than a conventional IC engine.
5. They are extremely silent in operation due to absence of valves and absence of exhaust gases. This makes Stirling engine an attractive prime mover to power submarines.
6. They operate at comparatively lower pressures and there are no phase changes for the working fluid. This makes the engine extremely safe and there is no danger for explosions. This also allows for lighter construction of cylinders and hence they can be made lighter and more portable.
7. They can easily be scaled down to very small sizes, where IC engines cannot be made. Hence they find applications in miniature cooling/power producing systems.
8. In contrast to IC engines which are less efficient in cold conditions, Stirling engines are more efficient when the atmosphere is cold.
9. The high theoretical efficiency promises better output. With better research it is possible to increase the efficiency of the engine
10. Extreme flexibility as the engine can either be used to produce power or when power is supplied it can either be used as a cooler or a heater.

WEAKNESS:

1. Stirling engines have low specific power output, meaning they produce less power compared to an internal combustion engine of the same size. This is the reason for preferring IC engines over Stirling engines for powering automobiles.
2. Another big problem with Stirling engine is its cost. It is said it is difficult to produce a Stirling engine that costs less than twice the price of a diesel engine of equivalent power. This might sound absurd at first, but keeping in mind the low specific power of Stirling engines, a Stirling engine of equivalent power will be much larger than a diesel engine. Moreover the design of effective heat exchangers is also costly. This outweighs the ease of manufacture of Stirling engines like the absence of valves etc.
3. The efficiency of Stirling engines is highly dependent on the temperatures of the thermal reservoirs. Almost all IC engines become more efficient as the temperature of the coolant increases (upto a certain temperature). But the efficiency of the Stirling engines drop as the working temperature increases. This is due to the fact that the heat from the hot region is transferred to the cold region, which reduces the effective temperature difference.
4. Sealing of Stirling engines is an extremely difficult job. Unlike IC engines in which the working fluid is expelled in every cycle, Stirling engines use the same working fluid their entire life. For a life of about 25 years, the leakage should of the order of 5×10^{-7} mbar l/s, which is very hard to achieve.
5. Stirling engines are inherently not self starting (so are internal combustion engines). This is usually due to high starting friction between the piston-cylinder interfaces. More over the warm up time for Stirling engines is comparatively longer than other engines.
6. It is not easy to vary the power output of Stirling engines. Usual methods include varying the displacement of the engine. The response time to change in temperature is quite long and hence not preferred.

PRESSURIZATION

It was Robert Stirling's brother James Stirling who first realized the importance of pressurizing Stirling engines. Pressurizing the working fluid improves the performance of the Stirling engine. But there is a catch, higher the internal pressure, the more difficult it will become to seal the engine properly. Most demonstration model engines run close to the atmospheric pressure, as construction ease is preferred over performance.

Efficiency:

The efficiency of a practical Stirling engine depends on the internal pressure of its working fluid.

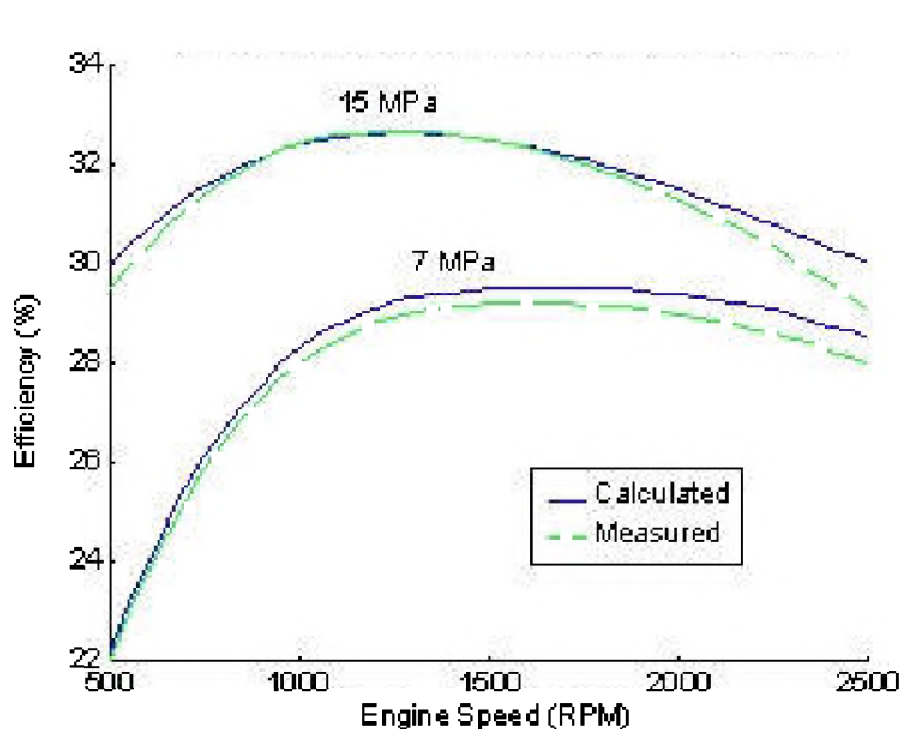

Fig(45):Efficiency v/s Engine Speed at different pressures.

It is seen that the efficiency of the engine dramatically improves as the internal pressure of the working fluid is increased. This is due to the fact that the work done by working fluid during the expansion stroke is a function of the internal

pressure. (Remember that the isothermal work done is dependent on the pressure).

Power:

Power output of a Stirling engine can be increased to a great extent by pressurizing the working fluid.

17.

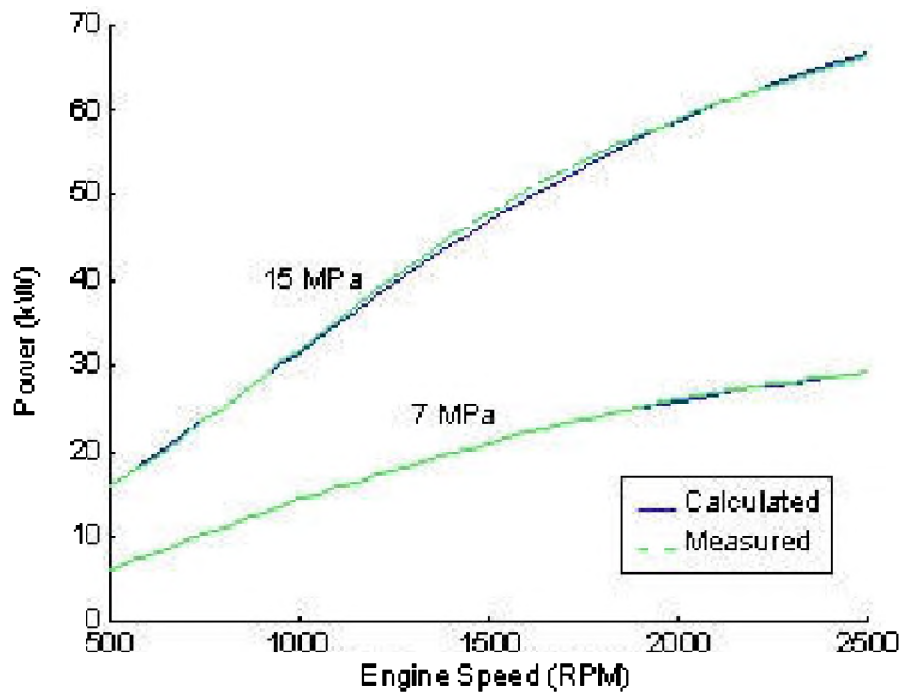

25.

Fig(46): Power v/s Engine speed at different pressures.

Again as the pressure inside the engine is increased, the work done by the working fluid increases and hence the power output of the engine also increases. Here the test results and calculated results almost co-relate.

Almost all Stirling engines used as mechanical prime movers are pressurized. Higher pressurization results in better performance, but these lead to increasing leakage and hence usually a compromise is made so that performance is enhanced and the leakage is low.

THE WORKING FLUID

The most favourable working fluid will have low specific heat capacity, so that a little heat absorbed will cause a large change in temperature and hence its volume. More over the ideal working fluid should have low viscosity, as higher viscosity means more energy is dissipated while shuttling the fluid between the cold and hot regions of the engine.

Helium seems to be the ideal gas for use in Stirling engine due to its low specific heat capacity, and it is inert and hence there is no risk of explosion. Most technically advanced Stirling engines make use of Helium as the working fluid. In terms of efficiency it is behind hydrogen but due to its relative safety and due to the ease of containing the working fluid within the engine, it is preferred over hydrogen.

Hydrogen with its low viscosity and high conductivity, is the most powerful working fluid, as engines can run at higher speeds. However containing hydrogen inside the cylinders is a difficult job even with proper sealing as hydrogen easily diffuses out through the metallic covers of the cylinder. More over associated problems include risk of explosion and embrittlement of metals which come in contact with it.

The most commonly used working fluid is air due its availability and not so bad characteristics. Most of the Stirling engines working with air usually operate at pressures close to the atmospheric pressure and hence problems associated with sealing are eliminated. On the downside, the power developed by a Stirling engine will be much lower compared to another engine operating under similar conditions. This has severely limited their use in Stirling engines intended for commercial use. Slightly better results are obtained when Nitrogen is used as a working fluid instead of air.

It was shown by Allan Organ, a researcher that theoretically a well designed Stirling engine, having air as the working fluid, is just as efficient as hydrogen or helium based Stirling engine.

PRESSURE VARIATIONS INSIDE CYLINDERS

The actual variation of pressure inside the cylinder is different from the indicated pressures seen from the Stirling cycle. Let us see the variations of pressure in the cylinders of an Alpha Stirling engine.

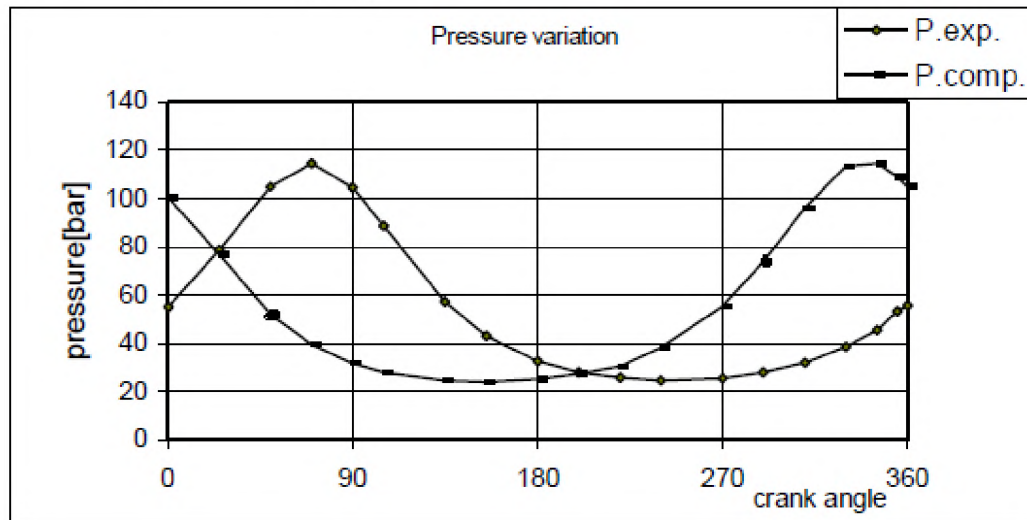

Fig(47): Pressure variations inside the cylinder

The stroke being executed at 0° is the transfer stroke moving the working fluid from the cold to the hot end. It is seen that the pressure peaks in the hot cylinder just before the start of the power stroke (follow curve P.exp which peaks near to 90°). At the end of the power stroke (180°), the mean pressure is minimum and the transfer of working fluid from hot to the cold end starts. Follow the other curve (P.comp), it is seen that the pressure rises in the cold cylinder from the start of the transfer stroke at 180° and reaches a peak just before the end of the compression stroke.

The above data can be extended to Beta and Gamma Stirling engines, which have only one piston. Hence a single curve can be drawn such that the pressure peaks near to the end of the compression stroke and reaches a minimum at the end of the expansion stroke. The curve may be approximated as the average of the two curves drawn in the above figure. Analyzing and visualizing the pressure variations can make clear the working of Ringbom and free piston Stirling engines.

TEMPERATURE VARIATIONS OF CYLINDERS

It is interesting to know the temperature variations of the cylinders in a Stirling engine. We can more or less know the temperature of the working fluid from the temperature variations of the cylinders.

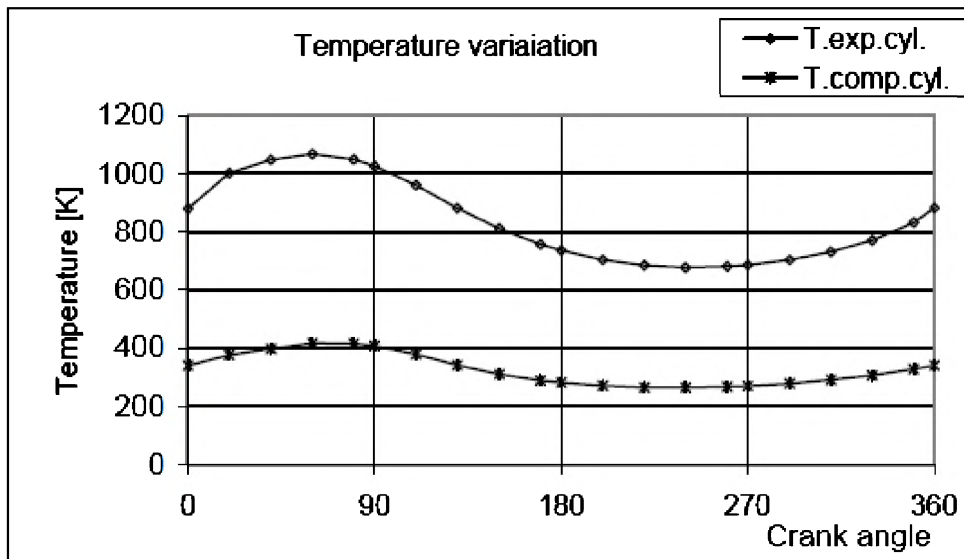

Fig(48): Temperature variations of the cylinder

At the start of the transfer stroke moving the working fluid from the cold to hot end, the temperature of the hot cylinder (top curve) is seen to be increasing. This is due to the fact that the cylinder is more or less empty at the stage. As the stroke proceeds and more and more fluid enters the cylinder, the temperature peaks and eventually start to decrease. During the working stroke, even more heat is taken from the cylinder and there is further drop in its temperature. This drop in temperature continues near to the end of the transfer stroke moving the working fluid to the hot to cold end. Again the temperature of the cylinder rises as there is very little working fluid inside the cylinder.

The temperature of the cold cylinder rises as the working fluid gets heated due to compression. The peak in the temperature is seen near to the end of the transfer stroke of working fluid from the cold to hot end. From then on the temperature falls as there is no or very less working fluid inside the cylinder.

BEALE NUMBER

The Beale Number is a parameter that characterizes the performance of Stirling engines. It is often used to estimate the power output of Stirling engines. For engines operating with a reasonably high temperature difference, the typical values of the Beale Number lie in the range of 0.11 to 0.15, where larger number indicate better performance.

Mathematically,

$$B_n = \frac{W_o}{PVF}$$

Where,

B_n - The Beale number

W_o - The work output of the engine in Watts

P - Average working fluid pressure in Pascal.

V - Swept volume of the piston in m^3

F -Frequency of the engine cycle in Hertz

WEST NUMBER

The West number is another empirical number that is used to predict the performance of Stirling engines and other Stirling systems. It is very similar to the Beale number in the sense that a larger number indicates a better performance. It is said that the average value of the West number is around 0.25 while high temperature differential engines may have a West number in the range of 0.35.

Mathematically

$$W_n = \frac{W_o}{PVF} \frac{(T_H + T_K)}{(T_H - T_K)}$$

It can also be written as,

$$W_n = B_n \frac{(T_H + T_K)}{(T_H - T_K)}$$

Where,

W_n - The West number

T_H - The absolute temperature of the heater in Kelvin

T_K - The absolute temperature of the cooler in Kelvin

If Beale Number at a particular temperature is known, it is possible to calculate the West Number at that particular temperature. Using the obtained number it is possible to calculate the power output for various other temperatures.

Non dimensional numbers are preferably used to express the performance of many physical systems. A lot non dimensional performance parameters are used to express the performance of Stirling machines in addition to the Beale and the West Number. Other non-dimensional numbers like the non dimensional engine speed, non dimensional work, non dimensional output and design pressure are some of the common numbers used in Stirling engine design.

Dr. Koichi Hirata, a Stirling engine enthusiast, designed a webpage which predicts the performance of a Stirling engine for the given inputs. The reader is advised to visit the page <http://www.bekkoame.ne.jp/~khirata/academic/simple/simplee.htm> (a simple Google search on for “Stirling engine performance prediction” should return this result), and try entering mock values to understand the significance of pressurizing the working fluid and also the choice of the right working fluid.

APPLICATION OF STIRLING ENGINES

SOLAR BASED POWER GENERATION

Stirling Engines can run from any heat source. This makes it an ideal system for solar based power generation. Most common setup includes a solar parabolic mirror and a Stirling engine, which is situated at the focus of the mirror. The sunlight is focused on the hot side of the engine and a linear alternator directly converts the work output of the engine into electricity.

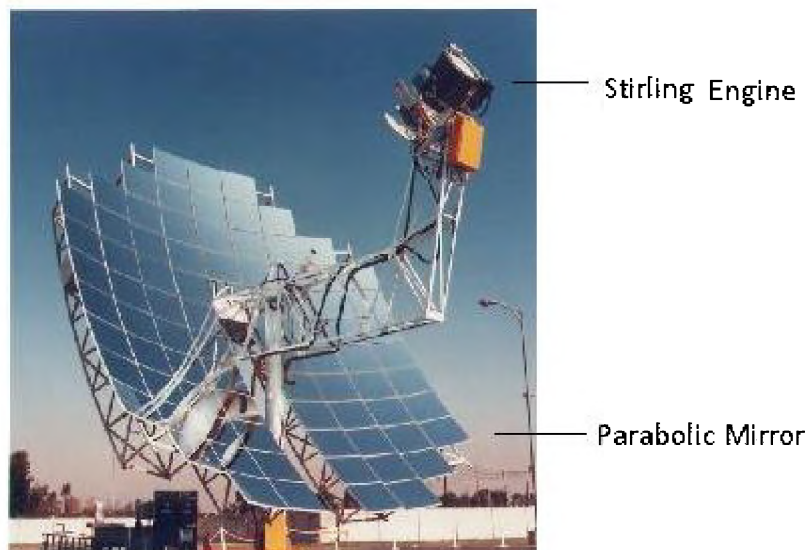

Fig(49): Stirling engine integrated into a parabolic mirror

It is said that a 30 foot diameter solar collector coupled to a Stirling engine can produce about 76000 Watts per hour which is enough energy to power five homes. They are highly efficient compared to solar cells, and have very low running costs. Infact according to Sandia National labs, this is the most efficient technology for converting sunlight into electricity. The biggest disadvantage of these systems is the out of phase power generation i.e. during night time when the demand for power is highest; they are unable to produce power. A lot of public sector companies like the Southern California Edison has invested a lot in these technologies due to their low running costs, which bring down the cost per unit power.

SOLAR THERMAL PUMPING SYSTEM:

The power output of a Stirling engine can be used for pumping. As we have seen earlier there are specific variants of Stirling engines which are suitable for pumping purposes. They can be modified so that solar energy provides the heat required for powering these engines.



Fig(50): SUNPULSE™: A solar thermal pumping system using a Stirling engine.

BSR Solar Technologies, developed a solar thermal powered Stirling engine that can be used to pump water. The most notable feature is that the Stirling engine is powered by unconcentrated solar radiation and hence auxiliary equipments for concentrating solar radiation can be avoided. Hence this low temperature differential Stirling engine can be integrated quite easily.

The sunlight falls on a absorber area of about 3 m^2 and raises the temperature to about 100°c . It is said that the displacer moves with a frequency of about 0.5 to 1 Hz and the pressure varies between $\pm 100 \text{ mbar}$, exerting a force of about 1000 kg on the 1 m^2 power piston.

STIRLING ENGINES IN AUTOMOBILES

The high theoretical efficiency of Stirling engines had attracted a lot of research in this field prior to 1980s when the price of fuel was high. In 1970s there was acute shortage of fuel and companies like GM and Ford spend millions of dollars for developing Stirling engines that could replace Internal Combustion engines. A number of prototypes were made, but none of them proved to be suitable for commercial production. Ford developed one vehicle running on Stirling engine, which can run smoothly but it produced very low power. More over you had to wait 20 seconds after you turned on the ignition key before the car moved!. Then in the 1980s fuel prices came down and interest in field went down. Currently most of the research is focused on building hybrid engines incorporating Stirling engines.



(a)



(b)

Fig (51) a) 1979 AMC Spirit equipped with an experimental Stirling .

b)The P-40 Stirling engine inside the bonnet of the car.

Stirling engines hold better promise in submarines and aircrafts. Stirling engines work efficiently in submarines due to the availability of large amounts of cooling water. As of now a number of submarines both military and non military submarines running on Stirling engines are in active service. Stirling engines theoretical promise efficient functioning onboard aircrafts. Unlike other aircraft engines whose performance goes down as altitude increases, the performance of a Stirling engine improves as the altitude increases due to fall in ambient temperature.

CHIP COOLING

Motherboard maker MSI (Taiwan) came up with an ingenious way of cooling the processor using Stirling engine. The Stirling engine takes up heat from the processor to function and the power output of the Stirling engine is coupled to a fan which aids in cooling.

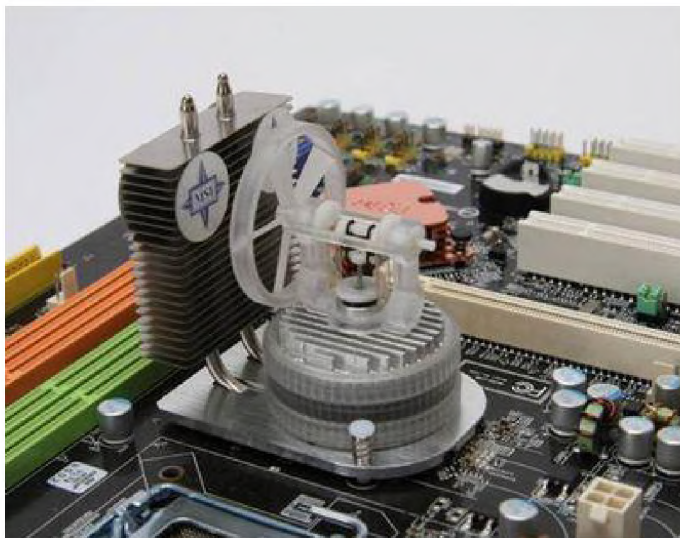

(a)

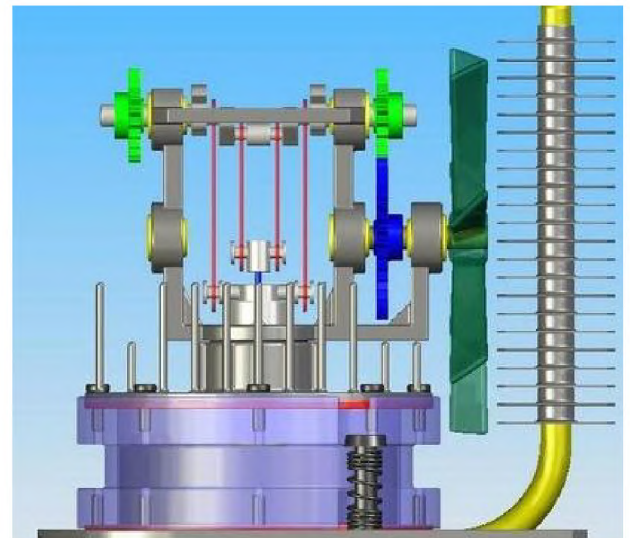

(b)

Fig(52): a) MSI Stirling processor cooler assembled on a motherboard
b) Schematic of the Stirling processor cooler.

The above design is appealing in several levels. First of all the cooler doesn't require any electrical power. Moreover the cooling of the processor is via two methods, first of all a part of the processor heat is drawn in by the Stirling engine for its functioning. The fan driven by the Stirling engine further enhances the heat transfer by increasing the convective heat transfer by the arrangement of heat pipes and fins (second figure). Theoretically, the cooler should auto regulate the temperature as higher the temperature of the processor, more will be the power output of the Stirling engine and more will be the cooling action of the fan.

It is claimed by the company that the Stirling engine based cooler can convert 70% of the drawn heat energy into motive power to drive the fan.

TOP USES OF STIRLING ENGINES IN HISTORY

- Cordless hair dryers
- Heats homes in The Netherlands with 50-75 hp engine.
- Provides basic power in Bangladesh and African villages by burning rice husks on the hot side of the engine (Lockwood engine).
- Powers oceanographic exploration submarine for Jacques Costeau, the Saga, so his team can quietly sneak up on the fishes and the whales.
- Power the quietest military submarines in the world—a 1300 hp Stirling engine drives subs in the Swedish and Danish fleets.
- Powers remote scientific research stations in Antarctica, providing power to run the experiments, the telescope, and send back data to scientists in warmer locations.
- Powers a new generation powerless processor cooling fan.
- Provides power to homes and industries in Las Vegas, Nevada. The heat source is a series of solar collectors.
- A car: the AMC Spirit was powered by a Stirling engine in the 1970's.
- Fans: from the 1880's to 1930's, fans were often powered by Stirling engines.
- Radios: In the 1930's, an engineer from Philips Electronics in The Netherlands found a Stirling fan at a flea market. Buying it, he adapted the engine to run a radio. Unfortunately, the transistor was invented soon after, making the more expensive Stirling radio obsolete.
- As a veritable replacement for any steam engine, the Stirling engine is much safer—which is why the Reverend Robert Stirling invented it in 1816!
- Refrigerators and freezers: Sun Power of Athens, Ohio developed Stirling-powered refrigeration units in the 1980's but they did not enter the market.
- Stirling cycle coolers generate liquid oxygen and liquid nitrogen in labs all around the world. It's a moderately priced way to do so!
- A yacht: Philips Electronics developed a 90 hp Stirling use for marine use.
- Domestic water pumps were powered by Stirling engines from 1870's to 1920's. Developments such as the SUNPULSE™ and ongoing researches in Fluidyne engine promises better water pumps.
- Sewing machines were powered by Stirling engines from 1870's to 1920's.

HOW TO MAKE A STIRLING ENGINE MODEL

This section is for those readers who are interested in making models and getting a feel of the Stirling engines. A lot of Stirling engine models can be made using simple house hold items. A number of videos and elaborate descriptions are available on the web. Here is one curious contraption that works on the Stirling cycle.

TEST TUBE STIRLING ENGINE :

(COURTESY: www.nmri.go.jp)

Parts Required:

(1) Test tube x1, (2) Syringe x1, (3) Marbles x5, (4) Rubber cap with an aluminum tube x1, (5) Rubber tube x1, (6) Rubber seat x1, (7) Wood screws x8, (8) Base board x1, (9) Frames x2, (10) Reinforced board x1, (11) Rubber ring x1, (12) Alcohol lamp x1



Step 1: Put in five marbles in the test tube, and cover with the rubber cap.

Step 2: Set the

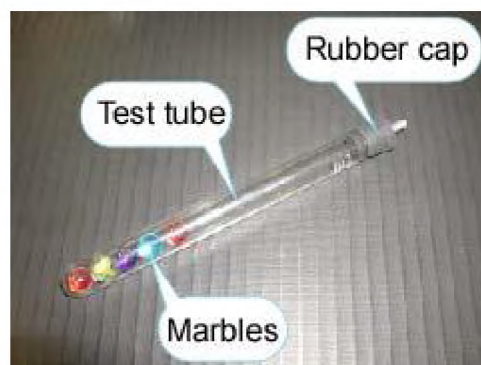

rubber tube to the rubber

cap. Set the syringe to the rubber tube as shown in the following photograph.

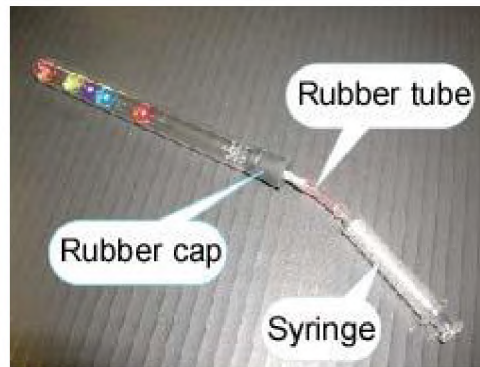

Step 3: Heat the end of the test tube. When you move the marbles in the test tube, the syringe should become long and short with the moving of the marbles. The syringe should become long when the marble is close to the syringe and short when it is at the other end. If this happens well, then the setup is working well. In case the syringe does not move or responds weakly, make sure there are no leaks and the syringe is not too tight.



Step 4: Assemble the frames and the reinforced board to the base board.

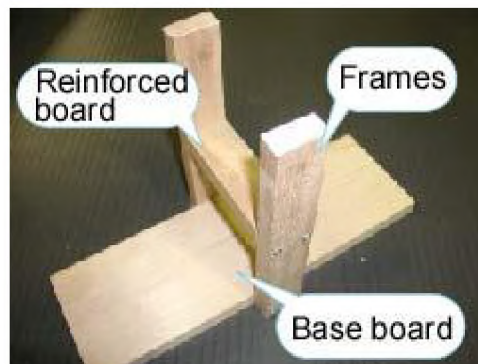

Step 5: Paste the both-faces-adhesive

rubber seat with a tape on the base

board.



Step 6: Set the rubber ring to the frames.

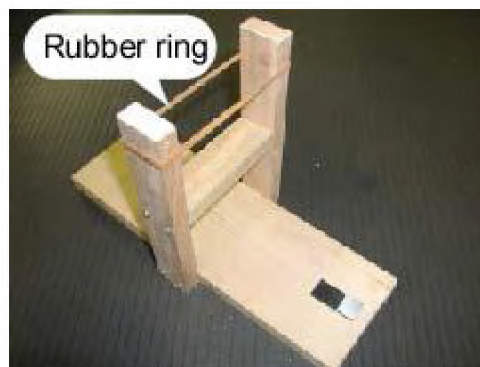

Step 7: Set the assembled test tube to the rubber ring as shown in the following photograph.

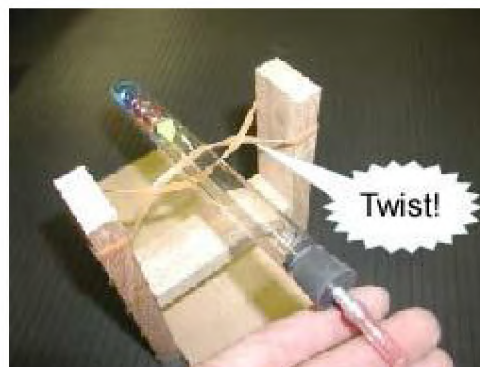

Step 8: Install the syringe to the rubber seat with the both-faces-adhesive tape.

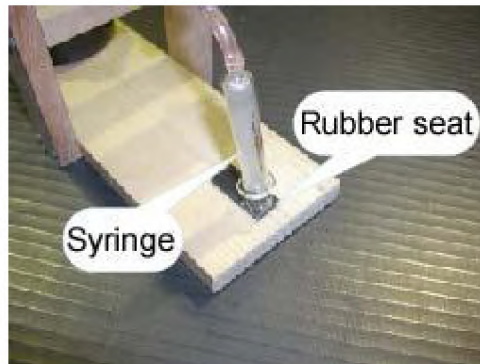

Step 8: Put the alcohol lamp. And The engine is completed.



Light the alcohol lamp and our test tube engine should be going up and down. You might need to do some minor adjustments to the length of the test tube before the rubber ring (try increasing or decreasing it), if the engine is not working satisfactorily. A search in Youtube on “Stirling Engine Experiment” should get you a video on one of these in action.

A number of other interesting designs are available in the web. Follow the links below or do a Google search if you are interested in more designs.

1. http://www.bekkoame.ne.jp/~khirata/english/mk_can.htm
2. <http://sites.google.com/site/reukpower/can-stirling/make-a-coke-can-stirling-engine>
3. <http://www.instructables.com/id/An-easy-to-build-Stirling-Engine-fan>

Excerpts from a book “**Two Can Stirling Engine**” by **William Gurstelle** is given below.(Pages X-Y).

TWO CAN STIRLING ENGINE:

Excerpts from a book "Two Can Stirling Engine" by William Gurstelle is given below. (Pages 84-92).



MATERIALS

Large steel cans (2) At least 4" in diameter. Large juice cans or 1lb. coffee cans work; 13 oz. coffee cans are too small.

Copper gauze Such as "Chore Boy" pot scrubber

Aluminum soda cans (2)

#3 size rubber stopper To fit middle opening of the copper tee

Plastic spacers, 1" long (2) The spacer's outside diameter must match the inside diameter of the sheave, while its inside diameter must just fit the rod used for the crank. Look in hardware stores, in the small parts bins that contain specialized fasteners.

3/4" copper tee

3/4" copper pipe, about 18" long Cut as follows: 2 3/4" (2), 5" (2)

5"-diameter metal die-cast sheaves or pulleys (2) Such as McMaster-Carr #6245K45

Wood 1"x2", 9" long (2) Pieces A

Wood 1"x10", 10" long Piece B

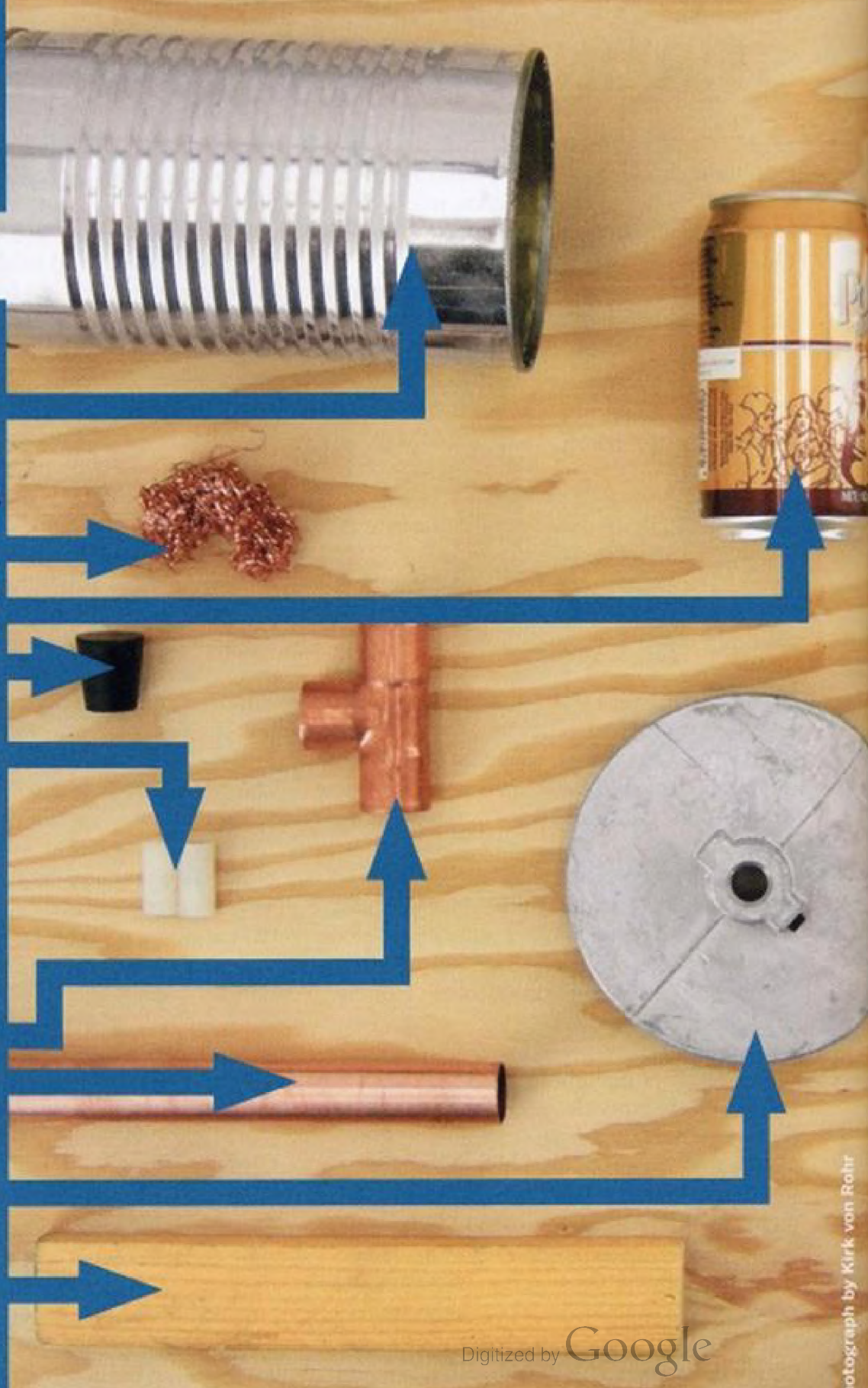

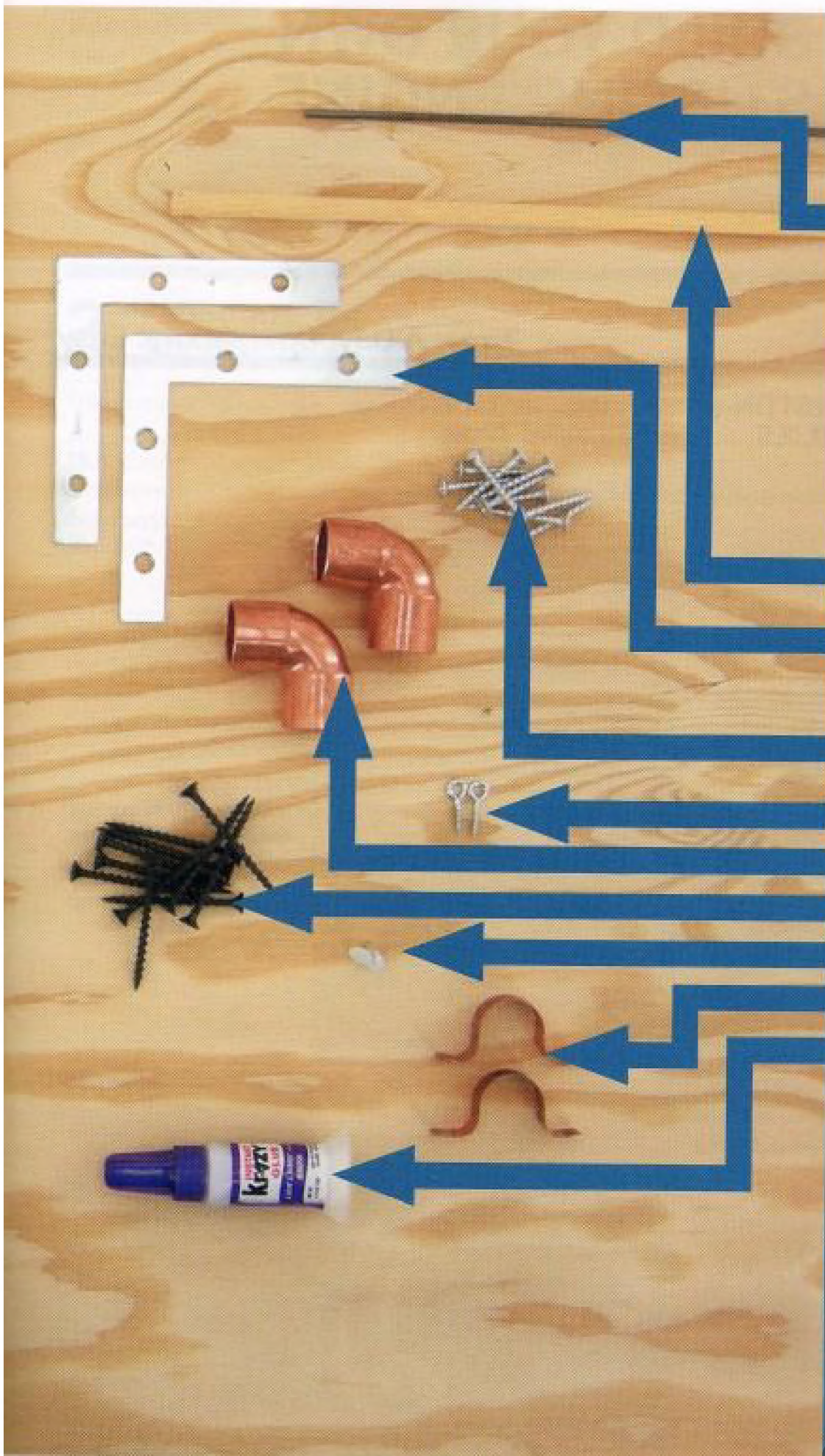

Wood 2"x4", 36" long
Piece C

Wood 2"x4", 4" long
Piece D

Metal rod, about 20"
For the crankshaft, I
used a .14"-diameter iron
rod, 19½" long. Other
diameters may work
as well, depending on
ductility and strength.
Metal rods come in
different tempers, some
more springy and more
difficult to bend. Select
one that bends easily,
yet is strong enough to
support the flywheels
without excessive bowing.

25"-long, ¾"-diameter
hardwood dowels (2)

4" steel flat corner
braces (2) with screws
Such as Stanley Hard-
ware #306560

1¼" drywall screws (10)

#214 metal screw eyes (2)

¾" copper elbows (2)

2" drywall screws (8)

Thumbtacks (2)

¾" pipe clamps (2)

Cyanoacrylate glue
and accelerator spray
Available in hobby
stores or online

TOOLS

Hacksaw
Vise, vise-grips, needlenose
pliers for rod-bending
Utility knife
Screwdriver
Drill and bits
Ruler and tape measure
Propane torch
Sandpaper
Allen wrench to fit
sheave setscrew

MAKE IT.



BUILD YOUR OWN STIRLING ENGINE

START >>

Time: A Day Complexity: Easy

1. MAKE THE PISTON SUBASSEMBLIES

There are two pistons in this engine, one for the hot side and one for the cold side.

1a. With a hacksaw, carefully remove the top end of each soda can. Cut the can at the point where the flat side of the can curves to meet the top, resulting in a 4"-long piston. Sand the cut edge to remove burrs, then wash and dry the interior.



1b. Locate the center of the can bottom as accurately as possible. Push the thumbtack through the can bottom at that point. Remove the thumbtack.



It helps to stuff a rag into the can when pushing the tack through. This will stabilize the sides of the can and prevent buckling.

1c. From the interior of the can, re-insert the thumbtack through the hole you just made.

1d. Locate the center on the end of the $\frac{3}{8}$ "-diameter dowel and push the thumbtack into the wood. Carefully remove the thumbtack and coat the bottom of the dowel and the tack with super glue. Press into place and apply the super glue accelerator spray to hold fast.



1e. Test the can for watertightness. If it leaks, apply more glue.

Digitized by Google

1f. Locate the center of the opposite end of the $\frac{3}{8}$ "-diameter dowel, and drill a pilot hole and screw the #214 screw eye into the center. Apply super glue and accelerator spray.



2. FABRICATE THE CRANKSHAFT

The crankshaft consists of a metal rod bent in a precise way that holds the piston connecting rods in alignment.

2a. Lay out bend lines on the rod as accurately as possible using a permanent marker, as shown on the bend diagram.

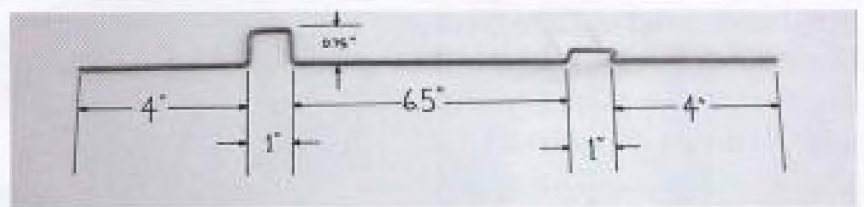

2b. Using a hammer, vise-grips, and vise, bend the metal rod as shown. Use special care when bending the rod to make the bend sizes and shapes correspond closely to the diagram. The 2 bends (the cranks) must be offset by exactly 90 degrees, and the distance from the end of the crank to the centerline of the crankshaft must be $\frac{3}{4}$ ".



2c. Insert the plastic spacers into the sheaves. Tighten the setscrew inside the collar of the sheave to lock the plastic spacer in place. Do not put flywheels on the crankshaft yet.



3. ASSEMBLE THE AIR CYLINDER

3a. Before soldering or gluing, cut down the $2\frac{3}{4}$ " pipes if necessary, so that the overall distance of the finished assembly will be $7\frac{1}{2}$ ", center-to-center.

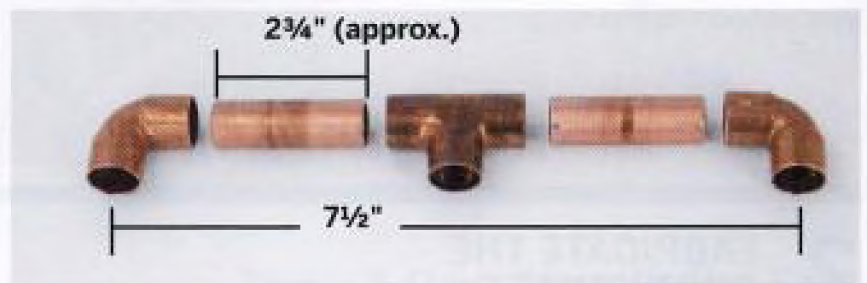

3b. Solder or epoxy the copper pipes and fittings together as shown, making certain the connections are airtight and leak-free. Note the alignment: the copper tee is rotated 90 degrees from the plane formed by the other 2 holes in the assembly.



3c. Place the rubber stopper into the middle hole, in the tee. This is the system's water drain.

4. ASSEMBLE THE WATER RESERVOIRS

4a. Remove the top from each steel can, leaving the bottom intact. Sand edges smooth.



4b. Mark a $\frac{3}{4}$ "-diameter circle in the center of the bottom of each can.

4c. With a utility knife, carefully make 8 to 12 radial slits on the bottom of the can, but within the $\frac{3}{4}$ " circle. The slits should form a star shape, radiating out from the center.



If you are soldering the pipe into the can, the bottom of the can should be very heavily scored with a file to provide a toothy surface that the solder can stick to.

4d. Push the 5" copper pipe into the can's bottom, through the hole formed by the slits. Slide the pipe until just 1" of pipe still extends out the bottom.



4e. With the pipe concentric and parallel to the sides of the can, solder the pipe in place. (Alternatively, you can seal the pipe-to-can connection with slow-curing, waterproof epoxy glue, taking care to seal the pipe carefully so it will not leak. Allow to dry completely.)



Do not give up hope on the soldering. It is very difficult to do, but perseverance will pay off.

5. MAKE THE FRAME

5a. Using deck screws or nails, assemble wooden pieces A-D to form a frame, as shown.

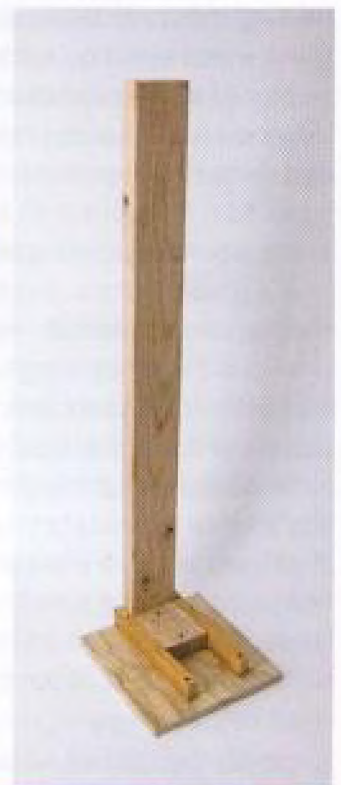
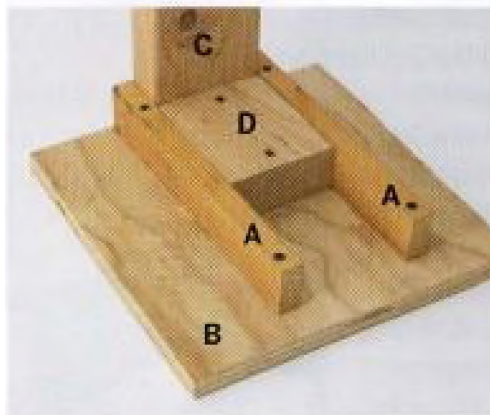

6. ASSEMBLE THE STIRLING ENGINE

6a. Insert the water reservoir assemblies into the air cylinder assembly. Fill the reservoir cans with water and check for leaks. Repair leaks with epoxy and let dry.



6b. Measure and then mark a spot on each 1"x2" frame piece, 3¾" from the back edge of the frame. Place the combined water reservoir and air cylinder assembly on the 1"x2" frame pieces at the marked spots. Now place the ¾" copper pipe clamps over the assembly. Screw the pipe clamps into the 1"x2" pieces. The clamps must hold the combined assembly firmly in place.



6c. Slide the screw eyes on the connecting rods onto the crankshaft, so that 1 screw eye is on each of the 2 cranks. Place the soda-can pistons inside each of the water reservoirs so that each soda can rests on copper pipes. Turn the crankshaft so that one of the cranks is pointing downward.

Holding the crankshaft level, lift the crankshaft until the can corresponding to the bottomed crank is about ½" above the top of the copper pipe. This is the desired height for the crankshaft. Mark this height on the upright 2"x4" and attach the angle bracket at this point, making sure that the hole through which the crankshaft will pass is located 3¾" from the back of the 2"x4".

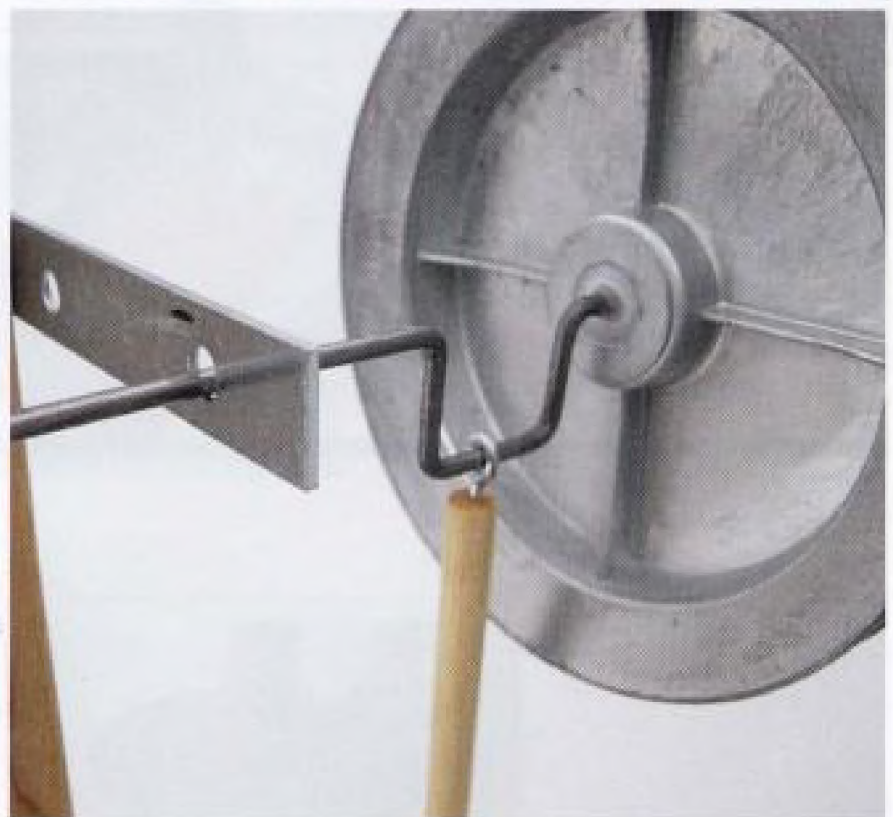

6d. Slide 1 flywheel onto each end of the crankshaft. Position the flywheels so that they are as far inboard as possible without interfering with the cranks or piston rods. Glue the flywheels onto the crankshaft using super glue and accelerator spray.

You're done!



FINISH 

USE IT.



MAKER, START YOUR ENGINE

To start your Stirling engine, turn the crankshaft until both cranks are tilted upwards at 45-degree angles to the vertical. With the stopper removed from the drain, fill each side with water, until a trickle runs out the drain. Dry it and replace the stopper.

Designate one side as the hot side, then heat the water on that side to boiling with a propane torch. This takes a while, depending on the heat output of the torch. Be patient.

When the water is ready, start the engine by giving the flywheels a small push. The rotation is determined by this rule: the cold side is 90 degrees behind the hot side.

If built properly, your engine will dip and lift, dip and lift, 20 to 30 times per minute to the chuff-chuff beat of Robert Stirling's ancient idea.



TROUBLESHOOTING

- 1. Make sure the engine is level.** The crankshaft must revolve freely, and the connecting rods should stay in the middle of each crank as it rotates. Use shims or cardboard to level the system. If the connecting rods will not stay centered on the cranks, you can add a small wire loop or small nut to the rod on either side of the eye screw, fastening them into place with super glue.
- 2. You may have to experiment to find the best flywheel weight.** If the flywheels are too heavy, the metal rod will bow, interfering with the crankshaft's rotation. But if the flywheels are too light, there won't be enough inertia to carry the crankshaft past the volume compression phase and into the next expansion stroke. If this happens, the engine will pulse but not run cyclically. You can add weight to the flywheel by simply taping bolts or other weighty objects to its perimeter.
- 3. Large steel cans full of water take time to heat.** Be patient, and let the water heat to 200°F or more.
- 4. Minimize friction and interference.** Friction is your engine's greatest enemy. Minimize rubbing between pistons and water cans, between connecting rods and cranks, and between the crankshaft and the metal support angles that attach it to the wooden frame.
- 5. Add a regenerator.** A regenerator consists of a small piece of heat-conducting metal gauze placed in the air cylinder just behind the rubber stopper. A regenerator will improve cycle efficiency and make the machine turn faster. The copper gauze sold for cleaning kitchen pots ("Chore Boy") works well.

HOW DO I MAKE A REAL STIRLING ENGINE?

First of all, a full scale Stirling engine is a bit difficult and expensive to make. For making a reasonably good working model, a lot of design parameters have to be considered like the power developed, the RPM of the engine, the temperature of the thermal reservoirs, the working fluid viscosity etc. Schmidt's Analysis and Isothermal Analysis are some of the common analysis techniques used for designing Stirling engines. There are equations for calculating the various dimensions of the Stirling engine like the stroke length, length of regenerator etc. once the basic parameters are known. The Beale and West numbers can be used to evaluate the performance of the engine. The reader is advised to read " *'The Regenerator and the Stirling Engine'* by Dr. Allan J. Organ" and the " *'Stirling Engine Design Manual'* by William R Martini" for detailed procedure for designing a Stirling engine.

Once the dimensions of the engine and its components have been obtained, making one requires highly skilled machining as very close dimensions have to be followed. Most of the machining is usually done by CNC machines as accuracy should be high. For those who are not interested in machining operations, they can contact professional CNC manufacturers with their design. A lot of Stirling engine designers usually do this as machining is a time consuming intricate process.

A number of Stirling engine designers have focused on making Stirling engines by modifying already existing IC engines or air compressors. In his book *'Making Stirling Engines'*, Andy Ross describes converting an automobile freon compressor to a Stirling engine. The conclusion of Andy and others is that while this approach can be made to work, there are too many compromises when you start with some parts that were made for some other use.

There are a variety of easy to assemble Stirling engine kits available in the market. They can easily be purchased on the internet as well. This is a cheap way to get on-hand experience on Stirling engines and will give you an idea of the challenges faced by a Stirling engine designer

TOP STIRLING ENGINE MANUFACTURES

NEW ZEALAND:

- WhisperTech : Company known for developing heating and power solutions. They are one of the few companies out there that manufacture double acting type Stirling engines.

USA:

- Sunpower : The company was founded by William Beale, the inventor of the free piston Stirling engines. It is known for Free Piston Stirling Engines and Stirling coolers.
- American Stirling Engine Company: They are known for their demonstration models and the easy to assemble kits manufactured by them.
- Stirling Technology Inc : Company known for manufacturing and marketing biomass fired Stirling engines, notably the ST-5.

DENMARK:

- Stirling Denmark : A Danish company known for manufacturing and supplying biomass fired Stirling engines.

SWEDEN:

- Kockums : This company is known for manufacturing and installing Stirling engines in submarines.

BRITAIN:

- Kontax : They are established manufacturers of Low Temperature Differential Stirling Engines.

TAIWAN:

- Polo Tech : This company is known for manufacturing Stirling engines for cooling purposes. Stirling engines for cooling PC's is a notable product of the company.

SUGGESTED FURTHER REFERENCE

ANIMATIONS:

- <http://www.stirlingengines.org.uk/pioneers/pion2.html> - Robert Stirling's first engine.
- <http://www.animatedengines.com/vstirling.shtml> - Alpha Engine.
- <http://www.animatedengines.com/stirling.shtml> -Beta Engine.
- <http://www.animatedengines.com/ltdstirling.shtml> - Gamma Engine.
- <http://www.animatedengines.com/ross.shtml> - Ross Yoke Mechanism.
- http://www.geocities.com/~rrice2/my_engines/ttr/page3.html - Rhombic Drive.
- <http://www.whispergen.com/main/technology> - Double acting Stirling engine using a swash plate.

BOOKS:

- **Free Piston Stirling Cycle Engines** by G. Walker
- **Ringbom Stirling Engines** by James R Senft
- **Understanding Stirling Engines** By William Beale
- **An Introduction to Stirling Engines** by James R Senft
- **An Introduction to Low Temperature Differential Stirling Engines** by James R Senft

DESIGN:

- **The Regenerator and the Stirling Engine** by Dr. Allan J. Organ
- **Stirling Engine Design Manual** by William R Martini
- **Making Stirling Engines** by Andy Ross
- <http://www.sesusa.org/SEDAF.htm>

STIRLING ENGINE MANUFACTURERS:

- WhisperTech - <http://www.whispergen.com>
- Sunpower - <http://www.sunpower.com>
- American Stirling Company - <http://www.stirlingengine.com>
- Stirling Technology Inc - <http://www.stirling-tech.com>
- Stirling Denmark - <http://www.stirling.dk>
- Kockums : <http://www.kockums.se>
- Kontax - <http://www.stirlingengine.co.uk>
- Polo Tech - <http://www.polo-tech.com>

TECHNICAL PAPERS:

- **Design and Development of a Liquid Piston Stirling Engine** (2006) by *Frank Kyei-Manu and Aloysius Obodoako*.
- **Multiphase Stirling Engines** (2009) by *Artin Der Minassians and Seth R. Sanders*.
- **Performance of low-temperature differential Stirling engines** (2006) by *Bancha Kongtragool and Somchai Wongwises*.
- **Simplified Theory of Ringbom Stirling Machines**(1999) by *Pierre Rochelle and Pascal Stouffs*.
- **Technological development in the Stirling cycle engines** (2008) by *D.G. Thombare and S.K. Verma*.